



# Product Guide

*Design and Installation Planning for  
SPS40E, SPS50E, SPS60E, SPS80E*

**DOCUMENT ID: 7513**

**REVISION: 04**

**DATE: 2024**

**LANGUAGE: EN**

**ID**

**Introduction**

This guide is made as a quick introduction and reference guide for designers and engineers with a good basic knowledge and understanding of boat building and good engineering practice. It does not cover all issues in all detail, and the complete installation manual contain more detailed information and should always be consulted for some details

**Stabilizer functions**

The fin stabilizers function is to reduce the roll of the boat, and how efficiently they can do this will depend on several factors.

This guide contain the major considerations om positioning the stabilizers for the efficiency, especially as relates to the revolutionary Vector Fin stabilizers that have some different priorities and features than traditional straight fin stabilizers.

**Installation planning**

Please follow this general guide and the installation manual for steps to prepare and plan your design and installation process:

Find the best possible position of the fins based on the information provided in the sections about:

- Safety and General precautions
- Measurements

Please note the very flexible installation methods possible including off-set angle installation possible with Side-Power stabilizers as this might enable installation in positions more suited and efficient than possible with some other brands or types of fin stabilizers.

- Fin & actuator positioning  
ENSURE to have reasonably easy service access
- Hull forces
- Ensure that it is space to do the reinforcement of the hull

Plan the installation of the electrical parts including the control panel and wiring runs based on the information in the sections:

- Power supply
- S-link wiring
- Control panel installation

## eVision Actuator

The electric drive component of the actuator system. The actuators are traditionally installed in the aft end of the living area or front section of the engine room. Due to the unique compact and low eVision design, installations require only minor modifications to the interior, if any. The actuators are also quiet so there is no problem to have in living spaces beneath the floor or furniture.

Dimension code	Dimension descriptions	SPS40E		SPS50E	
		mm	inch	mm	inch
A	Actuator height outside the hull	15.8	0.6	15.8	0.6
B	Total actuator height	219.5	8.6	22.6	8.7
C	Actuator height inside the hull	169.5	6.7	171	6.7
D	Hull thickness (sealant included)	50	2	55	2.17
ØE	Diameter of the actuator Motor	290	11.4	310	12.2
ØF	Diameter of the actuator through the hull	340	13.4	361	14.21
ØG	Diameter of the actuator base plate	450	17.7	471	18.54
	Weight (kg / lbs)	65	143.3	75	165.3

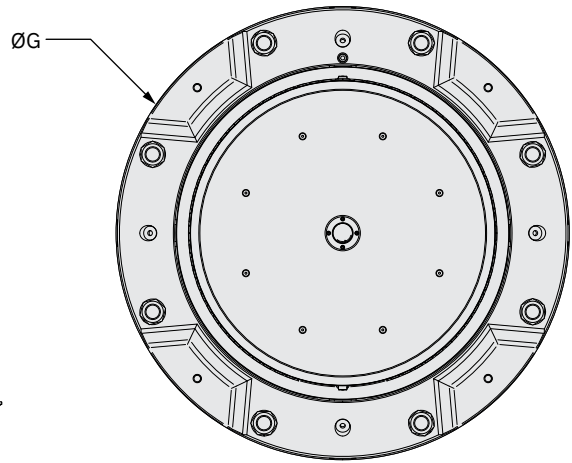
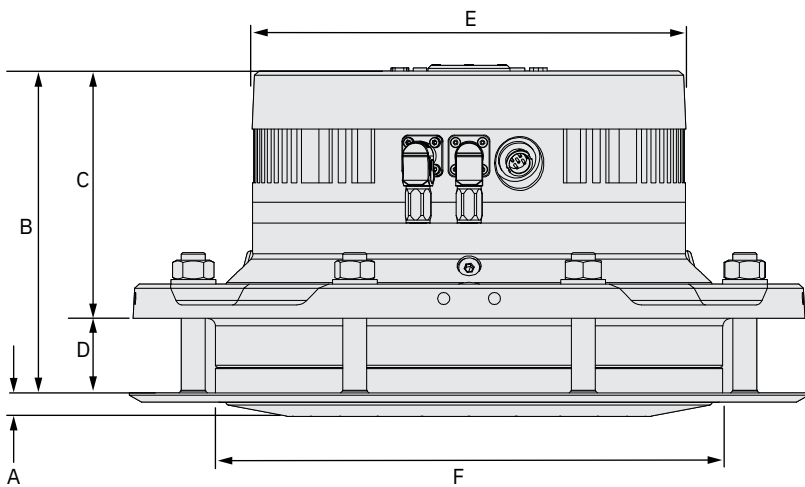

MG\_0753\_1

Dimension code	Dimension descriptions	SPS60E		SPS80E	
		mm	inch	mm	inch
A	Actuator height outside the hull	16.8	0.6	20	0.8
B	Total actuator height	236	9.3	349	13.7
C	Actuator height inside the hull	172	6.8	249	10
D	Hull thickness (sealant included)	60	2.4	105	4.1
ØE	Diameter of the actuator Motor	350	13.8	475	18.7
ØF	Diameter of the actuator through the hull	408	16	537	21
ØG	Diameter of the actuator base plate	564	22.2	705	28

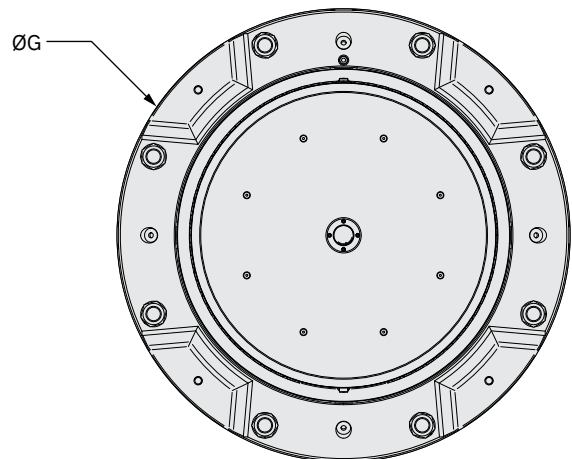
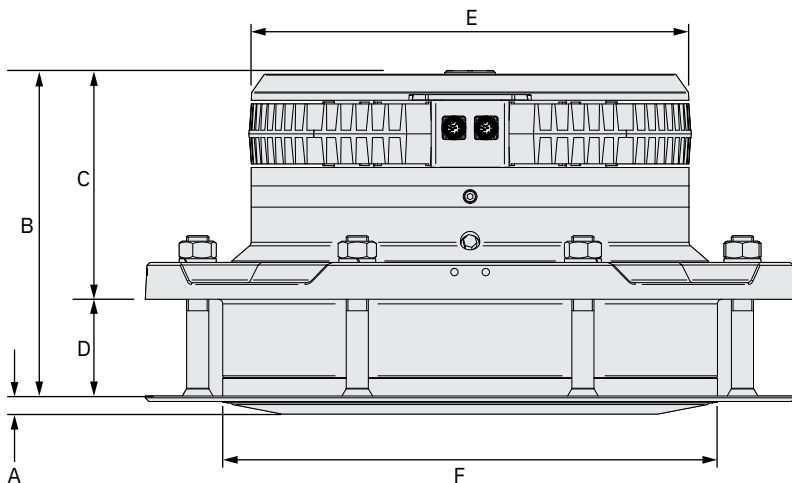

MG\_0643\_1

Consider and plan the positioning of the actuator for future service and appropriate area for cooling the electric motor. The ambient temperature is 40°C. The motor has temperature sensor and system will reduce power to avoid exceeding maximum allowed temperature.

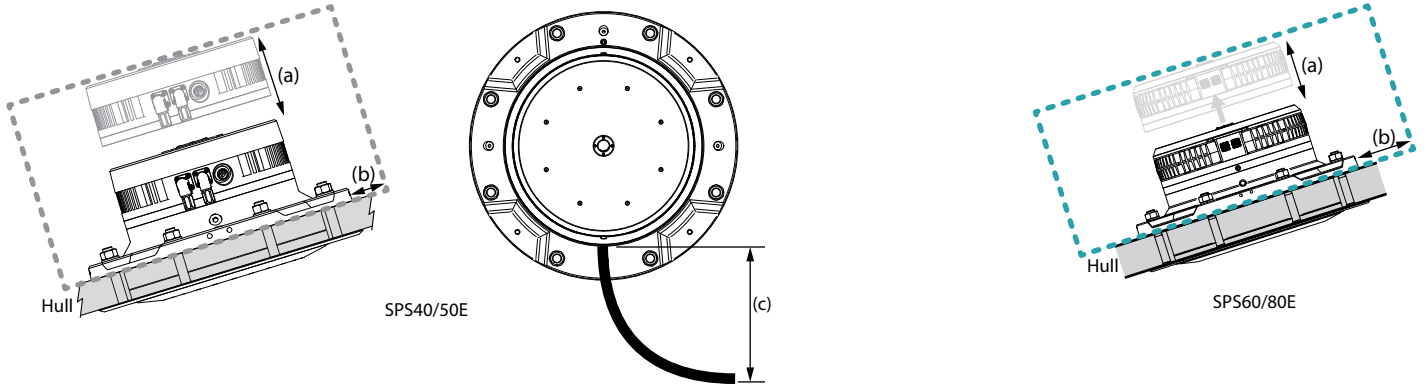

Dimension code	Dimension description	SPS40/50E		SPS60E		SPS80E	
		mm	inch	mm	inch	mm	inch
(a)	Free space for motor replacement	100	3.9	185	7	250	10
(b)	Base plate tooling clearance	50	2	50	2	50	2
(c)	151713-xxx (SCU) minimum cable bend clearance	200	7.9	200	7.9	200	7.9

## eVision Actuator Fin

The 3rd generation Vector Fins™ are more efficient underway and at anchor. For faster boats the lift from the fins results in improved fuel efficiency compared to flat fins. The fins consume extensively less energy at anchor to achieve the same stabilization level as flat fins. By using the same energy, they stabilize more.

## Fin Dimension

Dimension code	Dimension descriptions	SPS40E				SPS50E			
		V <sup>4</sup> -8 ≤35 knots		V <sup>3</sup> -9 ≤23 knots		V <sup>4</sup> -8HS ≤40 knots		V <sup>4</sup> -12 ≤35 knots	
		mm	inch	mm	inch	mm	inch	mm	inch
A	Total fin length	1342	52,8	1433	56,4	1342	52,8	1574	62,0
B	Fin length to centre connection	1134	44,6	1220	48,0	1134	44,6	1330	52,4
C	Total fin height	652	25,7	690	27,2	652	25,7	764	30,1
D	Fin width from centre connection	471	18,5	501	19,7	476	18,7	543	21,4
E	Total fin width	396	15,6	426	16,8	396	15,6	465	18,3

## Fin Dimension

Dimension code	Dimension descriptions	SPS60E						SPS80E					
		V <sup>3</sup> -14 ≤23 knots		V <sup>4</sup> -12HS ≤40 knots		V <sup>4</sup> -15 ≤35 knots		V <sup>3</sup> -23 ≤23 knots		V <sup>4</sup> -21HS ≤40 knots		V <sup>4</sup> -26 ≤35 knots	
		mm	inch	mm	inch	mm	inch	mm	inch	mm	inch	mm	inch
A	Total fin length	1751	68,9	1574	62,0	1805	71,1	2256	88,8	2155	84,8	2329	91,7
B	Fin length to centre connection	1490	58,7	1330	52,4	1525	60,0	1920	75,6	1821	71,7	1966	77,4
C	Total fin height	843	33,2	764	30,1	876	34,5	1086	42,8	1047	41,2	1131	44,5
D	Fin width from centre connection	613	24,1	558	22,0	627	24,7	795	31,3	760	29,9	811	31,9
E	Total fin width	520	20,5	465	18,3	534	21,0	670	26,4	635	25,0	686	27,0

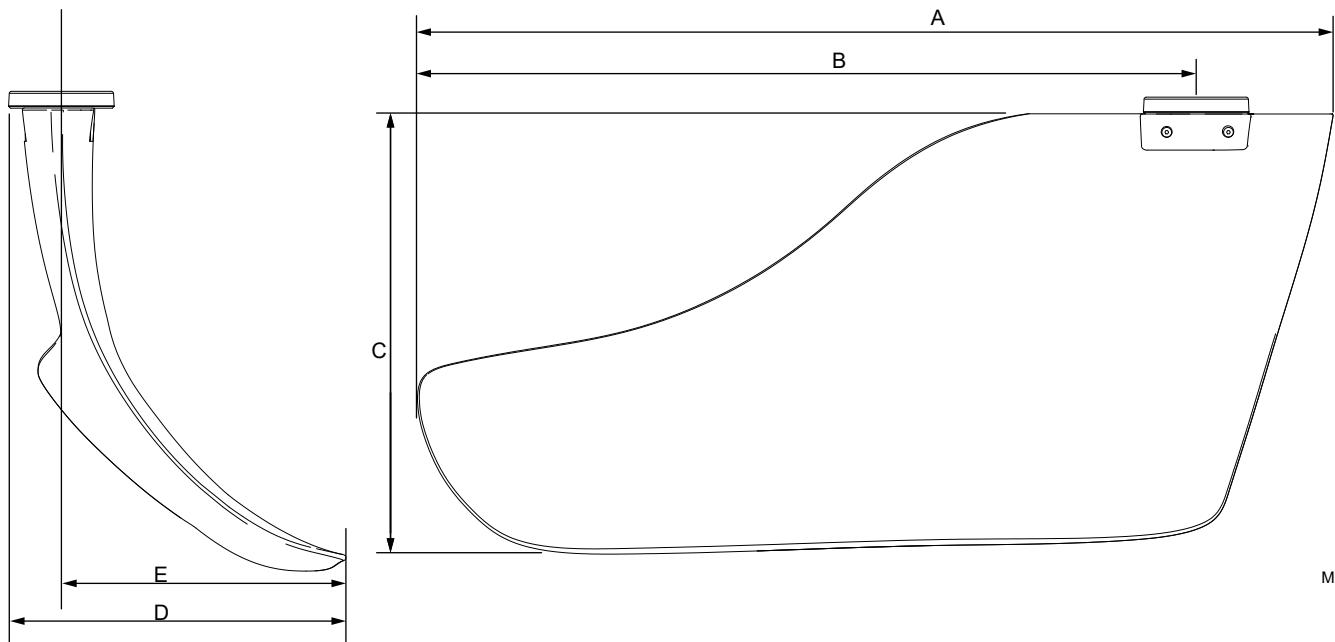

**eVision eFD**

The eFD is the control and power relay between the Actuator and the stabilizer control unit (SCU), used in the SPS60E and SPS80E systems. Supplied with 2.5 / 4.5 / 7 meter long encoder- and power cables for connection to the actuator. Mount the eFD in proximity of the actuator to ensure that the cables can be connected. Mount with the cables pointing down and in a ventilated area with maximum 50°C ambient temperature, IP56.

Dimension code	Dimension descriptions	mm	inch
H	Height	479	18.85
W	Width	278	10.94
D	Depth	311	12.24
(a)	Mounting hole height	463	18.22
(b)	Mounting hole width	239	9.41
(c)	Mounting hole diameter	6	0.24
(d)	Required sideway free space	278	10.94
(e)	Required front free space	500	19.6
(f)	Required cable clearance	250	10

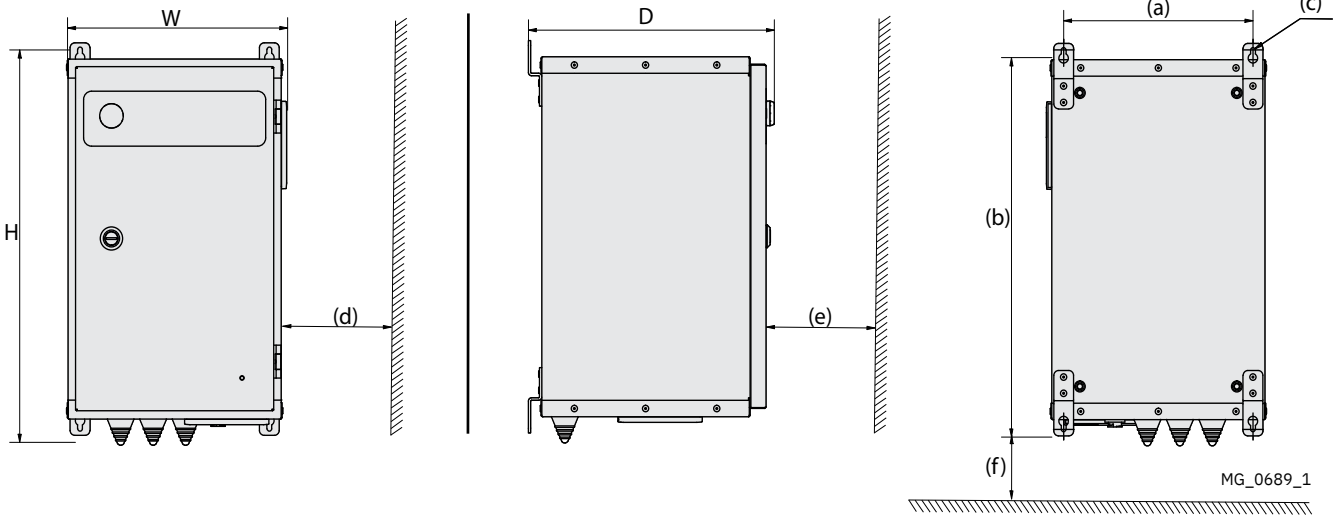

**Stabilizer Control Unit - SCU**

The main SCU with sensors should be placed on a bulkhead - as close to the vessel's boat roll centre - but not essential. Can be facing forward or aft, - remember to tell the system which position during setup. Avoid fitting to a vibrating structure as the unit contains the sensors used to register boat movement. The SCU LCD allows local control of parameters. Startup tasks can be performed directly from the user interface.

Dimension code	Dimension descriptions	mm	inch
H	Height	170	7
W	Width	271	11
D	Depth	60	2
(a)	Mounting hole height	153	6
(b)	Mounting hole width	247	9.7
(c)	Required cable clearance	250	10

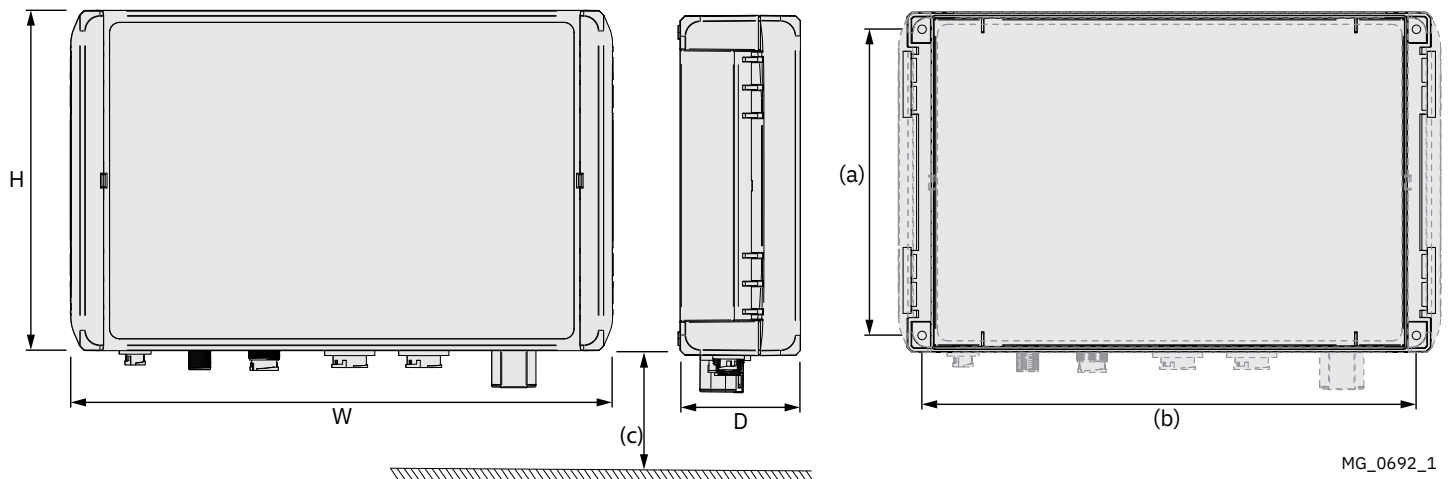

### GW-1 'Gateway'

The GW-1 is enabling the use of GPS data for s-link devices. GPS messages can be received from NMEA2000 compatible GPS-receivers, or optionally through the NMEA0183 input connector provided on the unit. Avoid fitting to structures that have a lot of engine vibrations

Dimension code	Dimension descriptions	mm	inch
W	Width	127	5
H	Height	49	2
L	Length	41	1.6

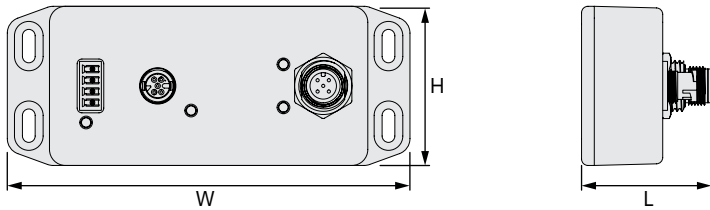

### TP-43 Stabilizer Operating Panel

The main operating panel can be fitted on the dashboard(s) from the front using four screws with a smooth plastic cover. It can also be "flush-mounted" by rear-fitting using studs. The Stabilizer operating panel is a 4,3" sunlight readable touch panel, that is used for setup and operation of the stabilizer system as well as other parts of the S-link system.

Dimension code	Dimension descriptions	mm	inch
W	Width	165	6.5
H	Height	103	4
L	Length	55	2

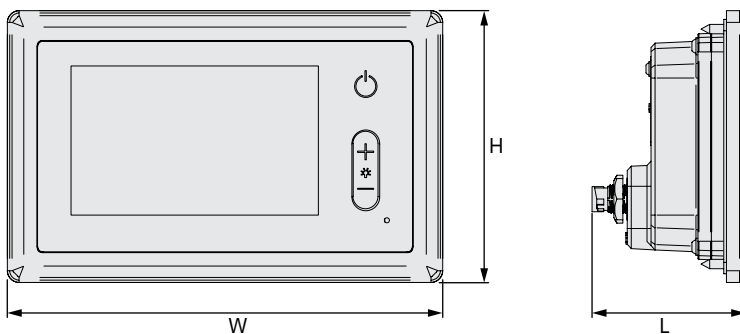

# Support Components

All of the components mentioned in this manual are necessary to operate the stabilizer system. If your system is missing some of these components contact, a Slepner dealer to obtain the latest model to complete your stabilizer installation.

### GPS receiver

Interfaced either through the NMEA 0183- or the NME 2000 port on GW-1. The GPS antenna should be installed where it can get a clear view of the sky and not be in the shadow of obstructions.

**Aft living area or engine room**

**eVision Actuator, eFD and SCU** are typically installed within the same compartment at the front of the engine room or aft of the cabin forward of the engine room. If these components are mounted on a bulkhead facing towards a living space, which is a typical position - ensure to mount on dampening material so no structural borne noise reach the living space.

**Helm**

The **Stabilizer operating panel** can be fitted on the dashboard(s) from the front using four screws with a smooth plastic cover, or it can also be “flush-mounted” by rear-fitting using studs. The **GW-1** should be placed relatively close to the helm dashboard and within 10m from the **GPS receiver**.

**Aft living area or engine room**

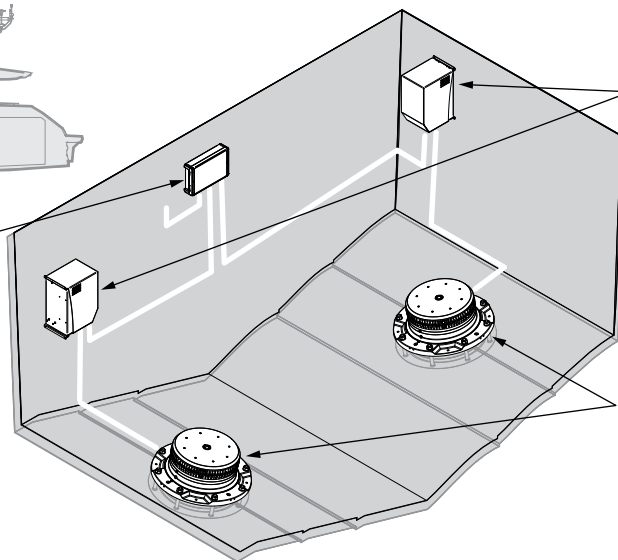
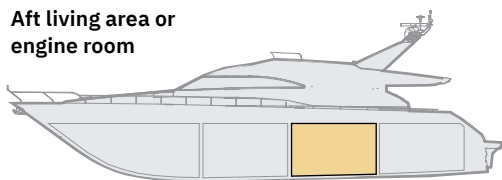

**SCU**  
Installed on a bulkhead - as close to the vessel's boat roll centre facing forward or aft. Avoid fitting to structures that have a lot of engine vibrations.

**eFD**  
Installed on a bulkhead or similar - close to the actuator units. Avoid fitting to structures that have a lot of engine vibrations.

**Actuators**  
Installed on the bottom of the hull, and avoiding any modifications to stringers or elements effecting boat hull integrity.

**NOTE:** The hull must be reinforced where the actuators will be installed to achieve the required hull strenght.

**Helm**

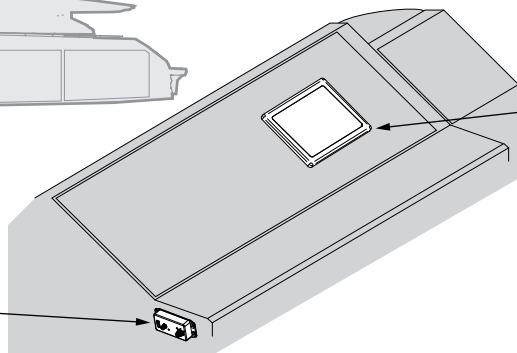
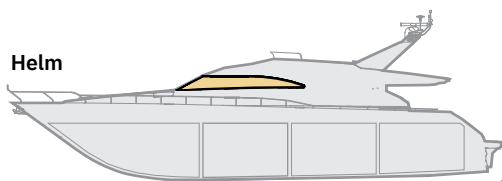

**GW-1**  
Installed relatively close to the dashboard within 10m from the GPS receiver. GW-1 is normally installed hidden under the dashboard and connects to S-Link backbone.  
**NOTE: The GPS receiver must be placed on the outside of the vessel.**

**Stabilizer Operating Panel TP-43a**  
Fitted on the dashboard(s) from the front using four screws with a smooth plastic cover, or it can also be “flush-mounted” by rear-fitting using studs.



# Wiring diagram for SPS40E & SPS50E

See S-Link System Description chapter for detailed information on installation of S-Link POWER Cable, END Terminator and additional S-Link components.

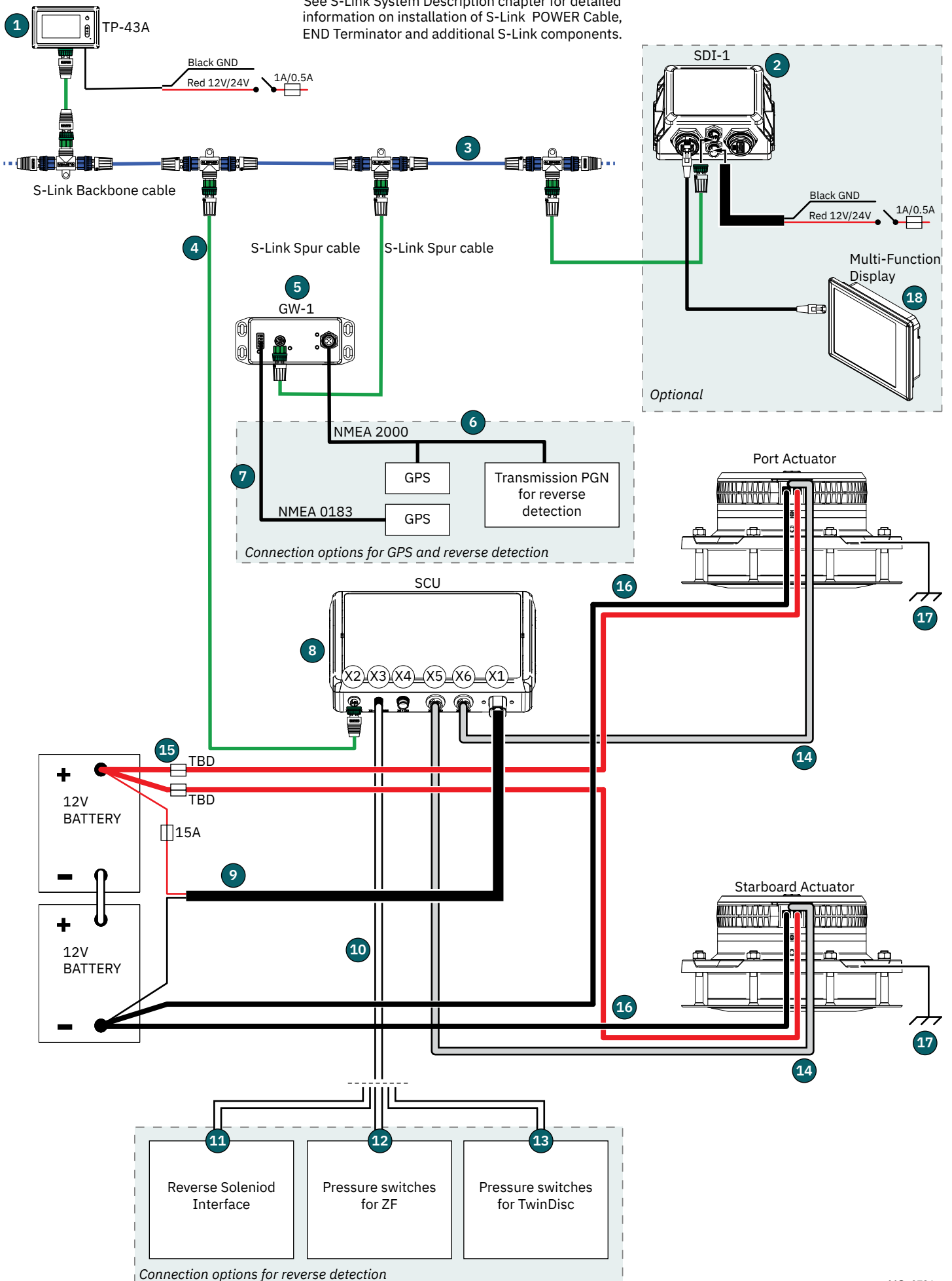

MG\_0721

# Wiring diagram for SPS60E & SPS80E

See S-Link System Description chapter for detailed information on installation of S-Link POWER Cable, END Terminator and additional S-Link components.

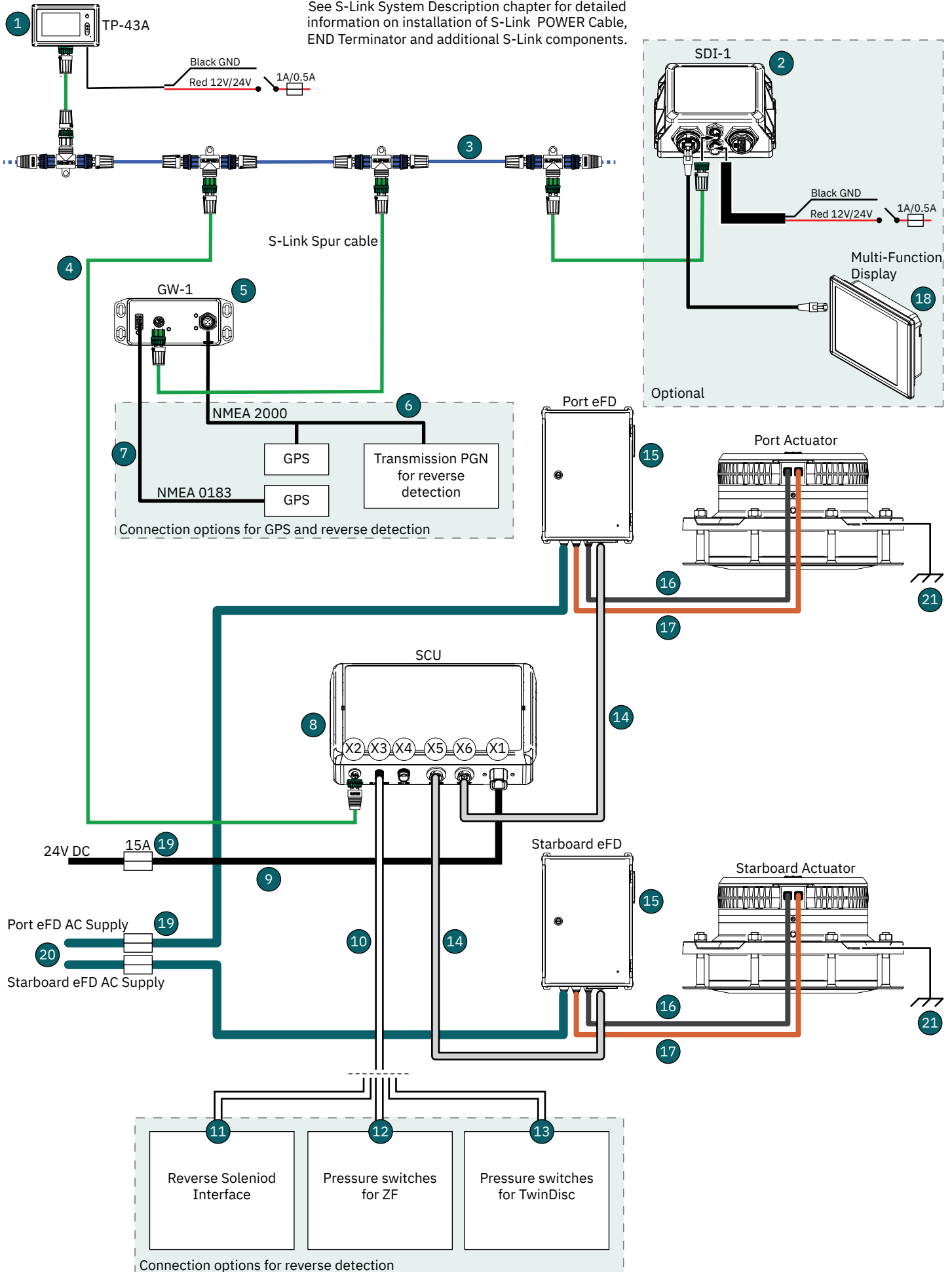

S-Link is a CAN-based control system used for communication between Sleipner products installed on a vessel. The system uses BACKBONE Cables as a common power and communication bus with separate SPUR Cables to each connected unit. Only one S-Link POWER cable shall be connected to the BACKBONE Cable. Units with low power consumption are powered directly from the S-Link bus.

**Main advantages of S-Link system:**

- Compact and waterproof plugs.
- BACKBONE and SPUR Cables have different colour coding and keying to ensure correct and easy installation. BACKBONE Cables have blue connectors and SPUR Cables have green connectors.
- Different cable lengths and BACKBONE Extenders make the system scalable and flexible to install.

**Installation of S-Link cables:**

Select appropriate cables to keep the length of BACKBONE- and SPUR Cables to a minimum. In case of planned installation with total BACKBONE Cable length exceeding 100 meters please consult your local distributor. The S-Link cables should be properly fastened when installed to avoid sharp bend radius, cable chafing and undesired strain on connectors. Locking mechanism on connectors must be fully closed. To ensure long lifetime, cables, T-Connectors and Extenders should not be located so that they are permanently immersed in water or other fluids. It is also recommended to install cables such that water and condensation do not run along the cables and into the connectors.

The POWER Cable should ideally be connected around the middle of the BACKBONE bus to ensure an equal voltage drop at each end of the BACKBONE Cable. The yellow and black wire in the POWER Cable shall be connected to GND and the red wire connected to +12VDC or +24VDC.

To reduce the risk of interference, avoid routing the S-Link cables close to equipment such as radio transmitters, antennas or high voltage cables. The backbone must be terminated at each end with the END Terminator.

SPUR cables can be left unterminated to prepare for the installation of future additional equipment. In such cases, ensure to protect open connectors from water and moisture to avoid corrosion in the connectors.

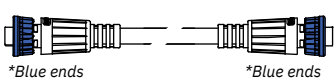

**BACKBONE Cable**  
Forms the communication and power bus throughout a vessel. Available in different standard lengths.

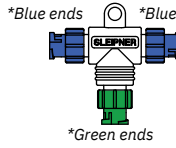

**T-Connector**  
Used for connection of SPUR or POWER Cable to the BACKBONE Cable. One T-Connector for each connected cable.

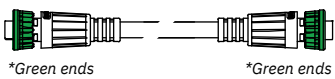

**SPUR Cable**  
Used to connect S-Link compliant products to the backbone cable. One SPUR Cable must be used for each connected component, with no exceptions. Recommended to be as short as practically possible. Available in different standard lengths.



**BACKBONE Extender**  
Connects two BACKBONE Cables to extend the length.

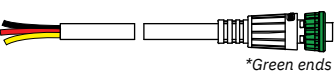

**POWER Cable**  
Required in all installations for connection of BACKBONE Cable to a power supply and should be protected with a 2A fuse.

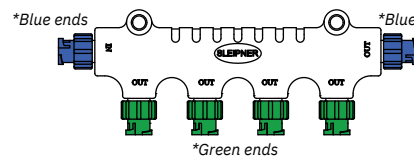

**4-Port T-Connector**  
The 4-PORT T-connector allows multiple SPUR Cables to be connected. The 4-PORT T-connector comes with two sealing caps to protect unused ports.

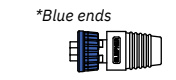

**END Terminator**  
Must be one at each end of the BACKBONE bus.

**S-Link installation example**

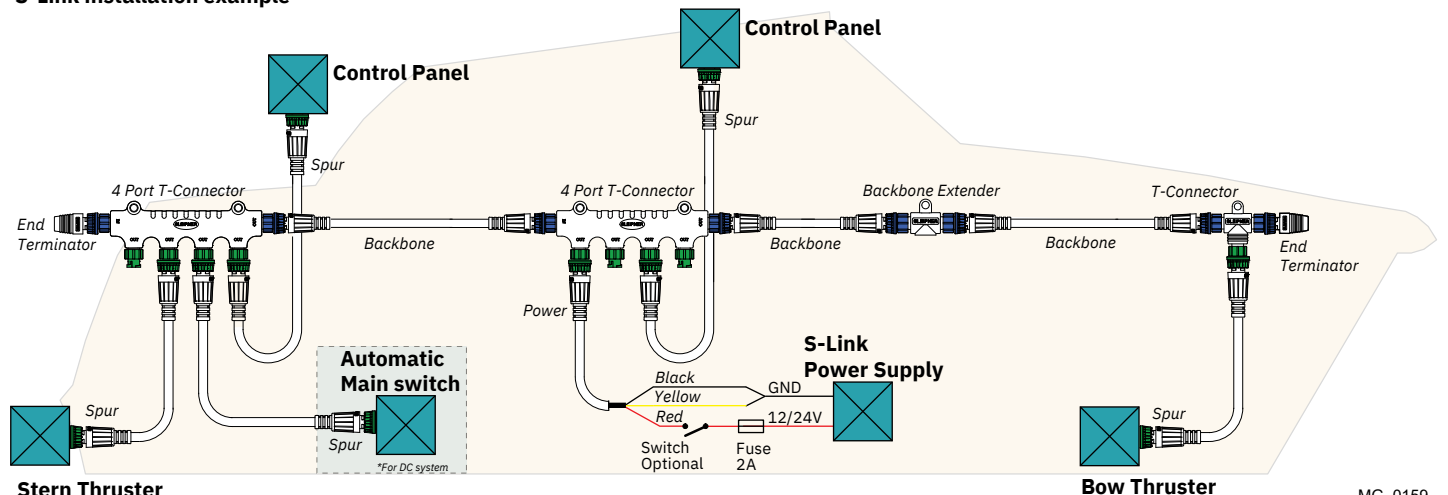

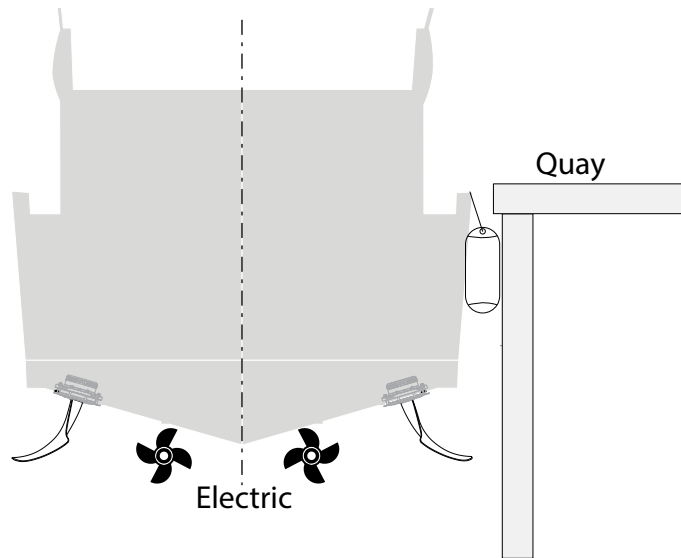

Fins should not extend outside the beam including the fenders, or below the keel/propeller when in neutral position.

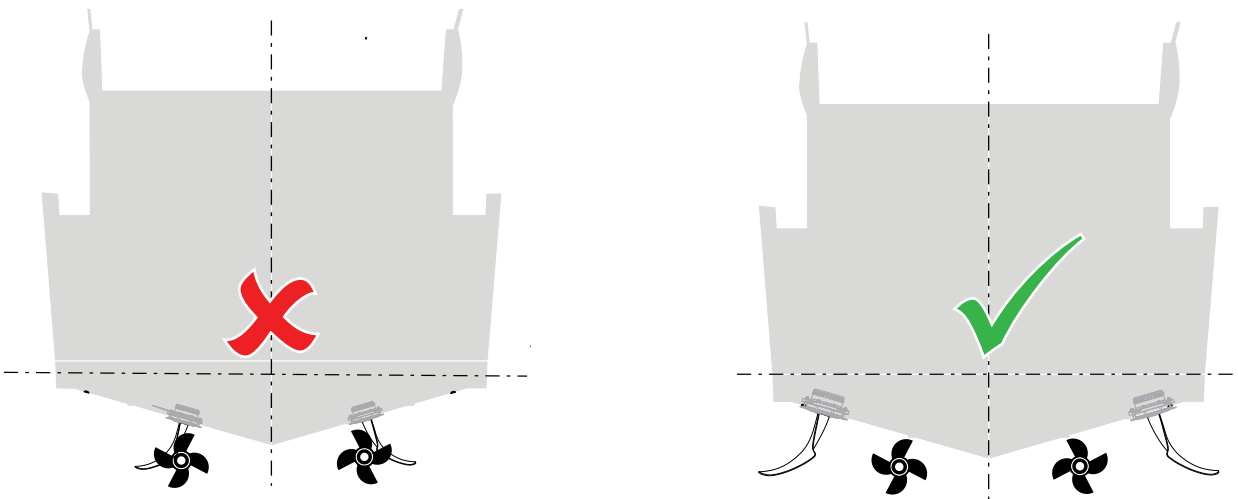

Fins should be placed as far outboard as possible, and NOT in-line with the propellers, to ensure avoiding possible disturbance of the water flow to the props which in the worst case can cause vibrations / cavitation.

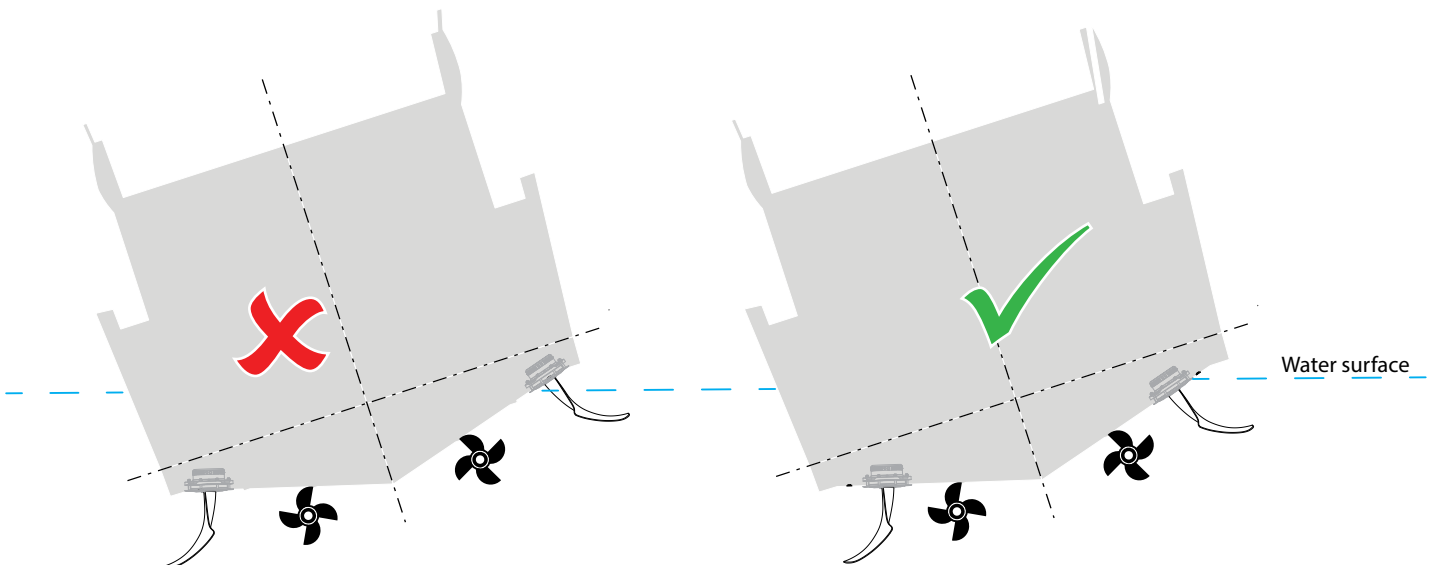

No part of the fin should be above water level during normal roll motion/under normal sea conditions.

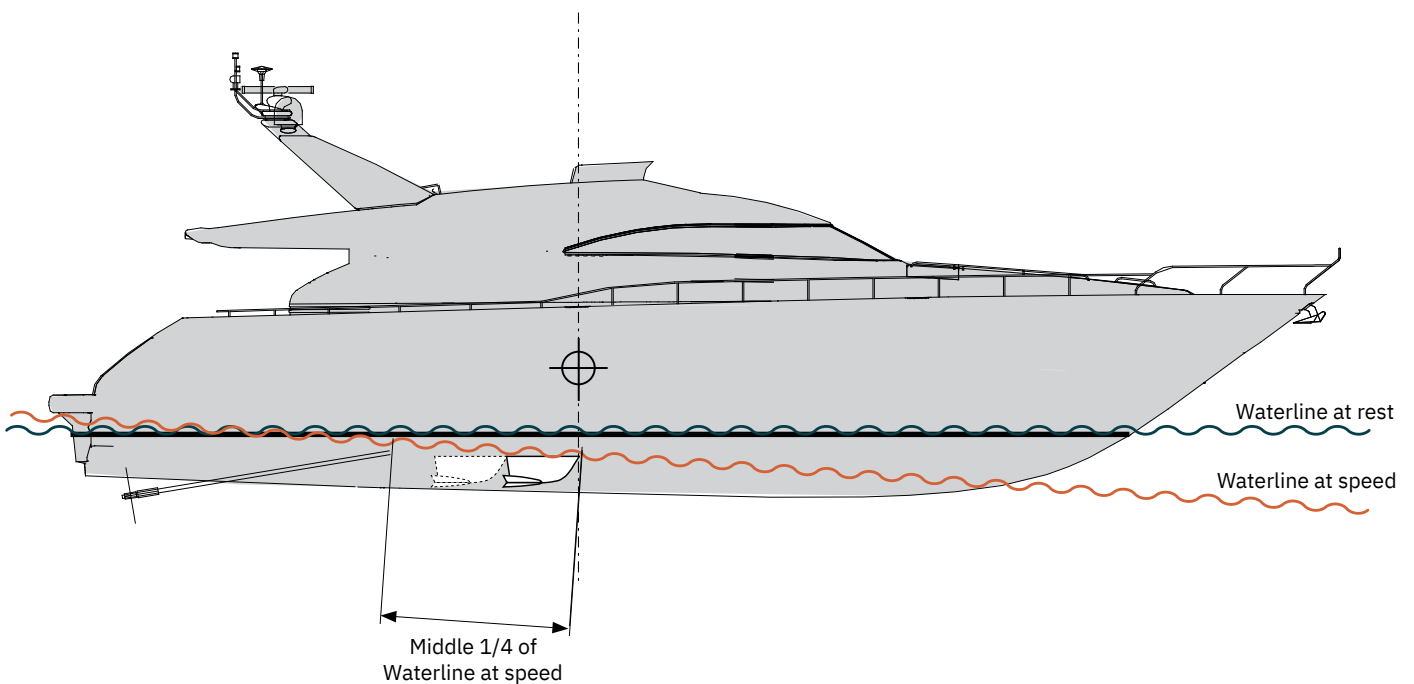
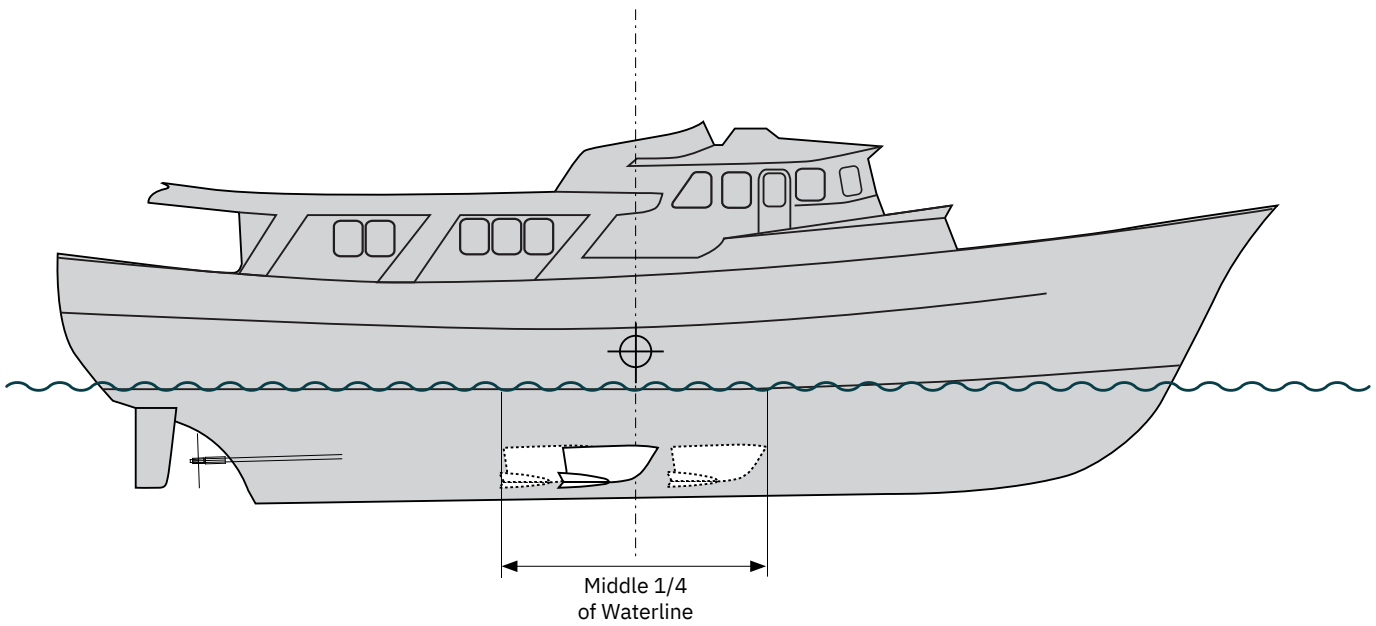

To avoid unwanted influences on the steering characteristics, the fins should be placed close to the vessel longitudinal centre of gravity (LCG)  
 - If unknown, this is usually a little aft of 50% of the waterline length.

For high speed vessels, the fins should be placed with trailing/leading edge within middle 1/4 of waterline length at speed and not in front of the LCG.

For vessels with top speed under 15 knots, fin may be placed within the middle 1/4 of waterline length.

**(NB: These are general guidelines and some hull types might allow for an installation position outside of this recommendation.)**

## Transversal fin positioning of Vector Fins™

With Vector fins™ it is a priority to push the fins as far outboard as possible to achieve the most leverage for the fins forces unlike standard fins.

Finding the best position for the fin and actuator positioning often is related to the inside configuration and space that is required for proper installation.

### General Rules:

–Push the actuators as far as possible outboard, keeping at least 22 degrees of outboard stroke as a minimum. It is also acceptable installing the fins further inboard if inside configuration/ access to inside parts of actuators is required. **(NB: Performance will be reduced slightly due to less leverage arm for the stabilizing force applied by the fins.)**

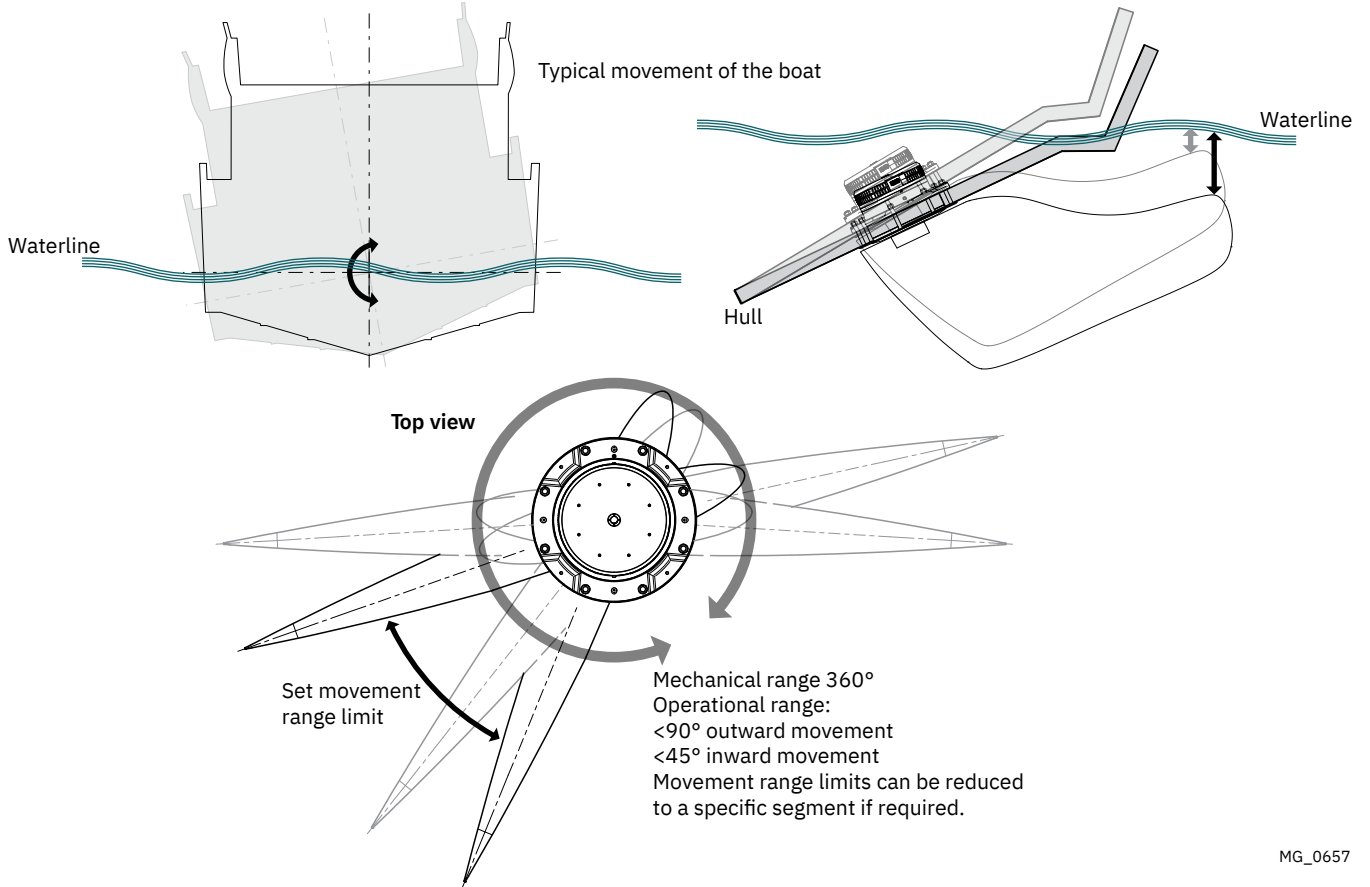

MG\_0657

All calculated values are normalised, determined by equilibrium considerations and also that various coefficients are inaccurate as hull design etc will affect the actual fin effect.

Dynamic effects such as jumps/impacts with waves, back flow closing of valve etc could further increase the hull/shaft loads. Therefore all dimensioning should account for this by using a safety factor.

Sleipner curved Vector Fin design comes with additional benefits in hull safety. Any impact with the ground will not only bend the shaft backwards and outward, allowing the fin to break away with less stress on the hull.

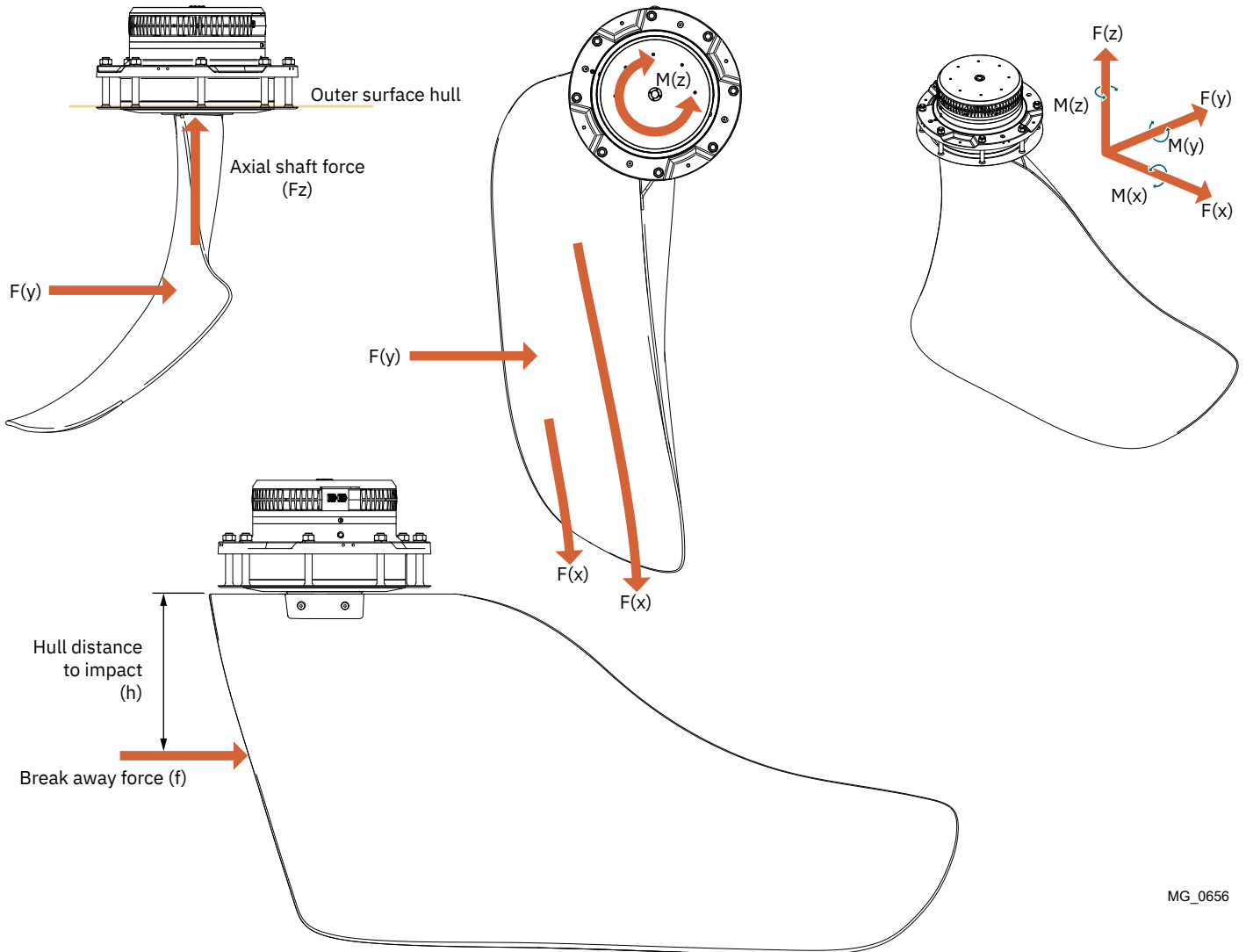

MG\_0656

SPS40E							
Structural requirements V3-9		Values to be considered individually				Break away impact force	
Speed	Max bending moment (kNm)	Mx (kNm)	My (kNm)	Mz (kNm)	Fz (kNm)	h (mm)	f (kN)
20	9.3	8.2	4.4	1.5	17.4	400	50
30	12,5	10,6	5,5	1,5	22	400	50

SPS40E							
Structural requirements V4-8		Values to be considered individually				Break away impact force	
Speed	Max bending moment (kNm)	Mx (kNm)	My (kNm)	Mz (kNm)	Fz (kNm)	h (mm)	f (kN)
20	14	13	4	1,5	16	400	50
30	18	17	5	1,5	24	400	50
35	20	18	6	1,5	26	400	50

SPS50E							
Structural requirements V4-12		Values to be considered individually				Break away impact force	
Speed	Max bending moment (kNm)	Mx (kNm)	My (kNm)	Mz (kNm)	Fz (kNm)	h (mm)	f (kN)
20	19	19	4,5	1,5	18	450	80
30	23	22	5,2	1,5	26	450	80
35	30	29	7	1,5	30	450	80

SPS50E							
Structural requirements V4-8HS		Values to be considered individually				Break away impact force	
Speed	Max bending moment (kNm)	Mx (kNm)	My (kNm)	Mz (kNm)	Fz (kNm)	h (mm)	f (kN)
20	14	13	4	1,5	16	400	50
30	18	17	5	1,5	24	400	50
35	20	18	6	1,5	26	400	50
40	25	24	7	1,5	34	400	50



SPS60E							
Structural requirements V3-14		Values to be considered individually				Break away impact force	
Speed	Max bending moment (kNm)	Mx (kNm)	My (kNm)	Mz (kNm)	Fz (kNm)	h (mm)	f (kN)
20	18	16	8	3	20	500	84
30	25	22	9	3	26	500	84

SPS60E							
Structural requirements V4-15		Values to be considered individually				Break away impact force	
Speed	Max bending moment (kNm)	Mx (kNm)	My (kNm)	Mz (kNm)	Fz (kNm)	h (mm)	f (kN)
20	28	28	7	3	24	500	84
30	34	32	8	3	35	500	84
35	44	42	10	3	44	500	84

SPS60E							
Structural requirements V4-12HS		Values to be considered individually				Break away impact force	
Speed	Max bending moment (kNm)	Mx (kNm)	My (kNm)	Mz (kNm)	Fz (kNm)	h (mm)	f (kN)
20	19	19	4,5	3	18	450	80
30	29	28	7	3	32	450	80
35	38	36	9	3	44	450	80
40	42	38	9	3	46	450	80

SPS80E							
Structural requirements V3-23		Values to be considered individually				Break away impact force	
Speed	Max bending moment (kNm)	Mx (kNm)	My (kNm)	Mz (kNm)	Fz (kNm)	h (mm)	f (kN)
20	37,3	33	17,8	5,5	44	700	143
30	55	45	25	5,5	55	700	143

SPS80E							
Structural requirements V4-26		Values to be considered individually				Break away impact force	
Speed	Max bending moment (kNm)	Mx (kNm)	My (kNm)	Mz (kNm)	Fz (kNm)	h (mm)	f (kN)
20	60	50	14	5,5	42	700	143
30	74	72	17	5,5	60	700	143
35	96	94	22	5,5	75	700	143

SPS80E							
Structural requirements V4-21HS		Values to be considered individually				Break away impact force	
Speed	Max bending moment (kNm)	Mx (kNm)	My (kNm)	Mz (kNm)	Fz (kNm)	h (mm)	f (kN)
20	48	49	13	5,5	40	700	143
30	60	56	15	5,5	50	700	143
35	76	42	17	5,5	66	700	143
40	100	98	22	5,5	86	700	143

Cable description	Located
Panel Power supply cable Part# 151090-020 - 2m	Included in the SCU kit
SCU Power supply cable Part# 151371-025 - 2,5m	Included in the SCU kit
GPS Receiver Part# 321714 - 10m	Included in the actuator kit
Reverse detection cable Part# 151375-100 - 10m	Included in the SCU kit
SCU-eFD cable Part# 151370-040 - 4m SCU-eFD cable Part# 151370-070 - 7m SCU-eFD cable Part# 151370-100 - 10m SCU-eFD cable Part# 151370-150 - 15m SCU-eFD cable Part# 151370-200 - 20m SCU-eFD cable Part# 151370-250 - 25m SCU-eFD cable Part# 151370-300 - 30m	Included in the actuator kit





© **Sleipner Group**, All rights reserved  
The information given in the document  
was right at the time it was published.  
However, Sleipner Group cannot  
accept liability for any inaccuracies or  
omissions it may contain. Continuous  
product improvement may change the  
product specifications without notice.  
Therefore, Sleipner Group cannot accept  
liability for any possible differences  
between product and document.

**Learn more about our products at**  
**[www.sleipnergroun.com](http://www.sleipnergroun.com)**



**SLEIPNER MOTOR AS**

P.O. Box 519

N-1612 Fredrikstad

Norway

[www.sleipnergroun.com](http://www.sleipnergroun.com)

Made in Norway