



# Installation Guide

*For Vector Fin Stabilizer Systems*

**STABILIZER  
SPS40/50E**

**VECTOR FINS**

**V3-9, V4-8, V4-12, V4-8HS**



DOCUMENT ID: 7439

REVISION: 19

DATE: 2025

LANGUAGE: EN

**MI**

# Contents

<b>Warning and safety</b> .....	2
<b>Installation Manual</b>	
Responsibility of the Installer .....	3
Technical Specifications .....	4
SCU Dimensions .....	4
Actuator Dimensions .....	5
Fin Dimensions .....	5
Actuator Positioning .....	6
Fin Positioning .....	7
Hull Forces .....	10
Hull structural forces .....	11
Actuator Components .....	12
Actuator Installation.....	13
Electrical Installation, general .....	21
SCU Cable Installation.....	21
Power connector assembly .....	22
Electrical Installation .....	25
S-Link System Description .....	26
Wiring diagram.....	27
Wiring reference .....	28
Keel alignment tool setup .....	29
Keel alignment setup.....	30
Fin Components .....	31
Fin Installation.....	32
Shaft cover installation.....	34
Zero inclination setup.....	35
Dynamic center setting .....	36
Stabilizer settings .....	37
Fin location label .....	38
Sleipner Group Waste Disposal and Recycling Guide .....	39
<b>Service and Support</b> .....	<b>40</b>
<b>Product Spare Parts and Additional Resources</b> .....	<b>40</b>
<b>Warranty Statement</b> .....	<b>40</b>
<b>Patents</b> .....	<b>40</b>

## Warnings and Safety

MC\_0800

It is essential to follow all instructions within this document to avoid potential personal injury, death, or damage to existing products in the vessel, the vessel's hull integrity, and including this product during installation or operation. Failure to follow instructions within this document will render all warranties given by Sleipner Motor as VOID.

Warnings and situations requiring extra caution are outlined in the documentation. Take extra consideration when warnings are outlined.



### WARNING

Indicate a potentially hazardous situation that, if not avoided, could result in death or severe injury.



### CAUTION

Indicates a potentially hazardous situation that could result in minor or moderate injury or critical damage to vessel integrity if not avoided.

MC\_0020

**General:**

- The installer must read this document to ensure necessary familiarity with the product before installation.
- Directions outlined in this document cannot be guaranteed to comply with all international and national regulations, including but not limited to health and safety procedures. It is the installers responsibility to adhere to all applicable international and national regulations when installing Sleipner products.
- This document contains general installation guidelines intended to support experienced installers. Contact professional installers familiar with the vessel, Sleipner products and applicable regulations if assistance is required.
- If local regulation requires any electrical work to be performed by a licensed professional, seek a licensed professional.
- When planning the installation of Sleipner products, ensure easy access to the products for future service and inspection requirements.

**For stabiliser systems**

MC\_0203

Please follow this general guide for steps to prepare and plan your installation process:

- Find the best possible position of the actuators and fins based on the information provided in the sections about:
  - Safety and General precautions Measurements.
  - Fin positioning, taken other systems into consideration (water trail not affecting propulsion system, exhaust system not interfering with fins etc.).
  - Hull forces
  - Ensure that it is space to do the reinforcement of the hull if required
  - Service access

Plan the installation of the electrical parts including the control panel and wiring runs based on the information in the manual.

Your Sleipner representative will be able to help make an educated decision for what is the best solution for your boat and your preferences. Before starting the installation, the Sleipner representative can ensure that you are not installing parts and products that will not meet your expectations. Sleipner Motor AS is a manufacturing company of marine equipment and not a Naval Architectural company & therefore take no responsibility regarding the installation of our products onto seagoing vessels.

This includes any requirement for the vessels:

- Hull reinforcement.
- Change in the vessel's stability.
- Dynamic performance.
- Weight and moment.
- Noise proofing.
- Watertight integrity after installation during normal operations or in the event of a collision.

It is the responsibility of the installer/boat builder to determine hull reinforcement requirements, ensuring that sufficient strengthening measures are in place & the vessel's hull will withstand & maintain watertight integrity in the event of a collision of our product, impacting an object when the vessel is underway.

The stabilizer product includes heavy parts. Ensure suitable lifting and support equipment is available during installation & removal to prevent material damage or personnel injury.

During yacht lifting operations:

- Ensure the stabilizer fins are in the locked/neutral position.
- Lifting personnel are informed that stabilizer fins are installed preventing the danger of snagging the lifting slings & damage to the yacht, its equipment or injury to personnel.

Yacht transportation overland with road vehicles may require the removal of the stabilizer fins. Please contact Sleipner representatives for instruction procedures.

**For electric eVision stabiliser systems**

MC\_0656



**WARNING**

**Ensure electrical power is switched off before any servicing work is carried out on the stabilizer system.**

**With power, the Stabilizer systems with 'at anchor' function installed & 'Auto' selected can suddenly operate & move without warning.**

Technical specifications	SPS40E		SPS50E	
	Min	Max	Min	Max
Ambient temperature	-25°C	+50°C	-25°C	+50°C
Supply voltage	18V	64V	18V	64V
Power consumption, each actuator / total both actuators.	1.5kW / 3.0kW		1.5kW / 3.0kW	

## SCU Dimension

Dimension code	Dimension descriptions	SCU	
		mm	inch
H	Height	170	7
W	Width	271	11
D	Depth	60	2
(a)	Mounting hole height	153	6
(b)	Mounting hole width	247	9.7

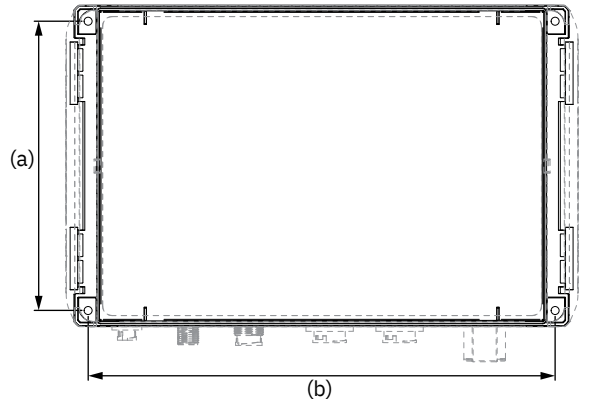
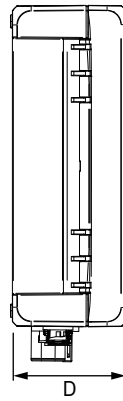
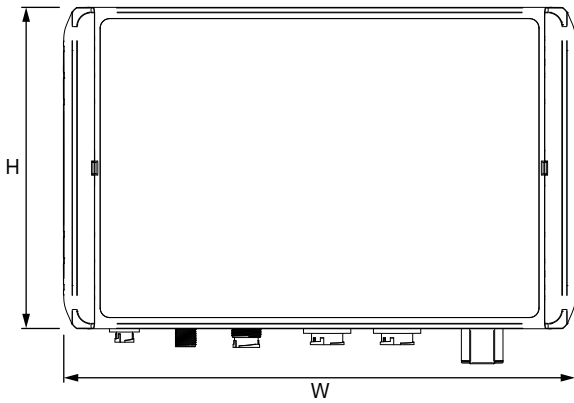

MG\_0692

## Actuator Dimension

MC\_0646

Dimension code	Dimension descriptions	SPS40E		SPS50E	
		mm	inch	mm	inch
A	Actuator height outside the hull	15.8	0.6	15.8	0.6
B	Total actuator height	219.5	8.6	223.1	8.8
C	Actuator height inside the hull	169.5	6.7	171	6.7
D	Hull thickness (sealant included)	50	2	55	2.17
ØE	Diameter of the actuator Motor	290	11.4	310	12.2
ØF	Diameter of the actuator through the hull	340	13.4	361	14.21
ØG	Diameter of the actuator base plate	450	17.7	471	18.54
	Weight (kg / lbs)	65	143.3	75	165.3

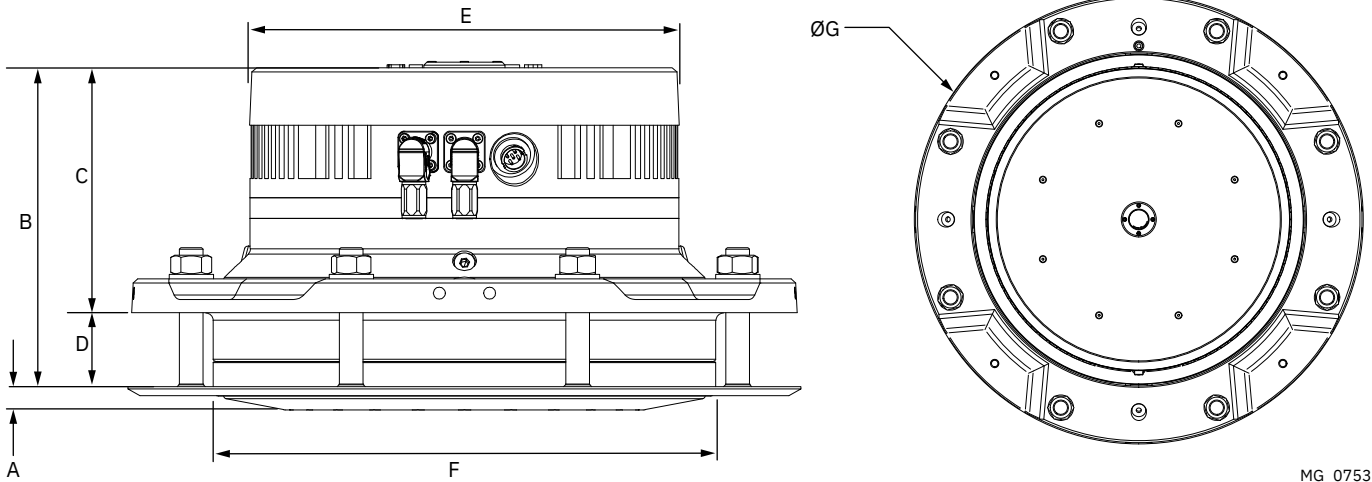

MG\_0753

## Fin Dimension

MC\_0652

Dimension code	Dimension descriptions	SPS40E				SPS50E			
		V <sup>4</sup> -8 ≤35 knots		V <sup>3</sup> -9 ≤23 knots		V <sup>4</sup> -8HS ≤40 knots		V <sup>4</sup> -12 ≤35 knots	
		mm	inch	mm	inch	mm	inch	mm	inch
A	Total fin length	1342	52,8	1433	56,4	1342	52,8	1574	62,0
B	Fin length to centre connection	1134	44,6	1220	48,0	1134	44,6	1330	52,4
C	Total fin height	652	25,7	690	27,2	652	25,7	764	30,1
D	Fin width from centre connection	396	15,6	426	16,8	396	15,6	465	18,3
E	Total fin width	471	18,5	501	19,7	476	18,7	543	21,4

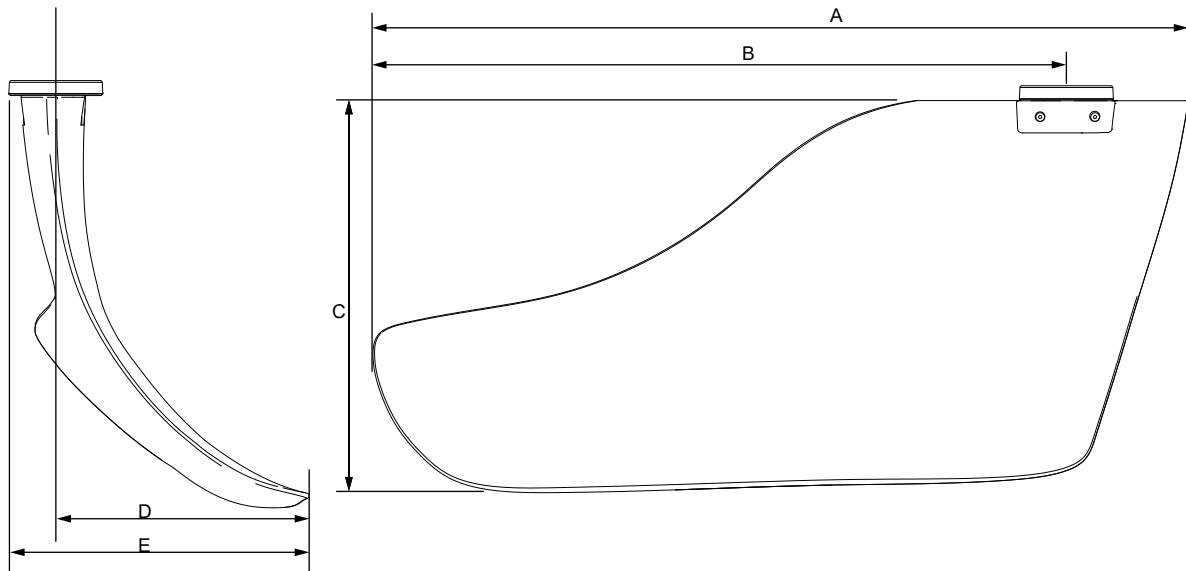

MG\_0679

Consider and plan the positioning of the actuator for future service.

Ensure enough space around the actuator to obtain the specified minimum bending radius of 151713-xxx (SCU) cable.

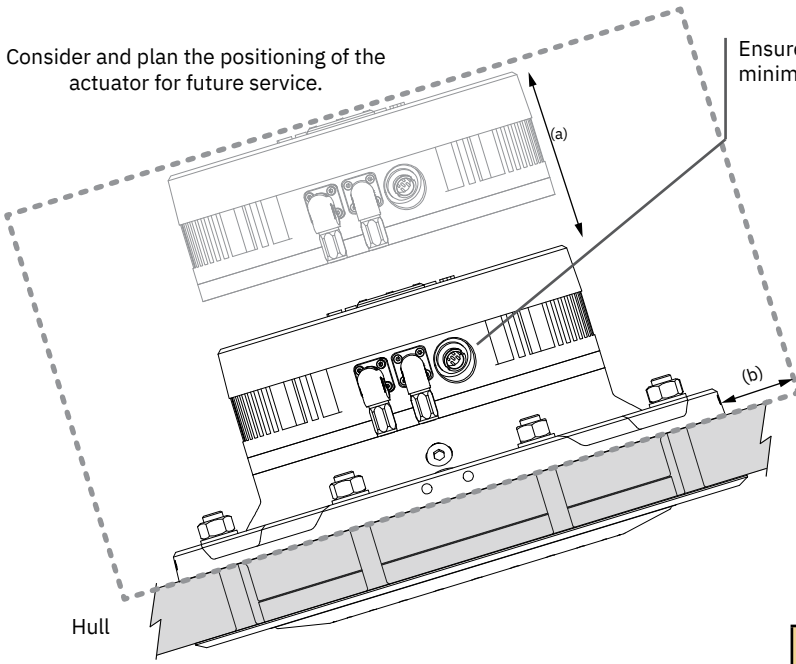

Hull

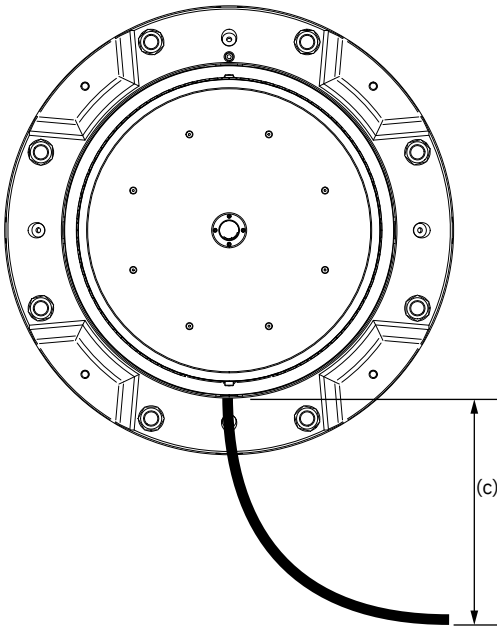

Dimension code	Dimension descriptions	mm inch	
		mm	inch
(a)	Free space for motor replacement	100	3.9
(b)	Base plate tooling clearance	50	2
(c)	151713-xxx (SCU) minimum cable bend clearance	200	7.9

MG\_0747

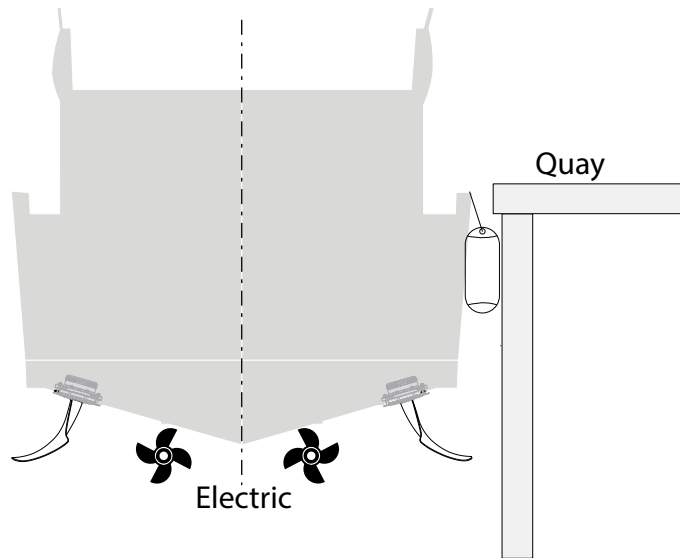

Fins should not extend outside the beam including the fenders, or below the keel/propeller when in neutral position.

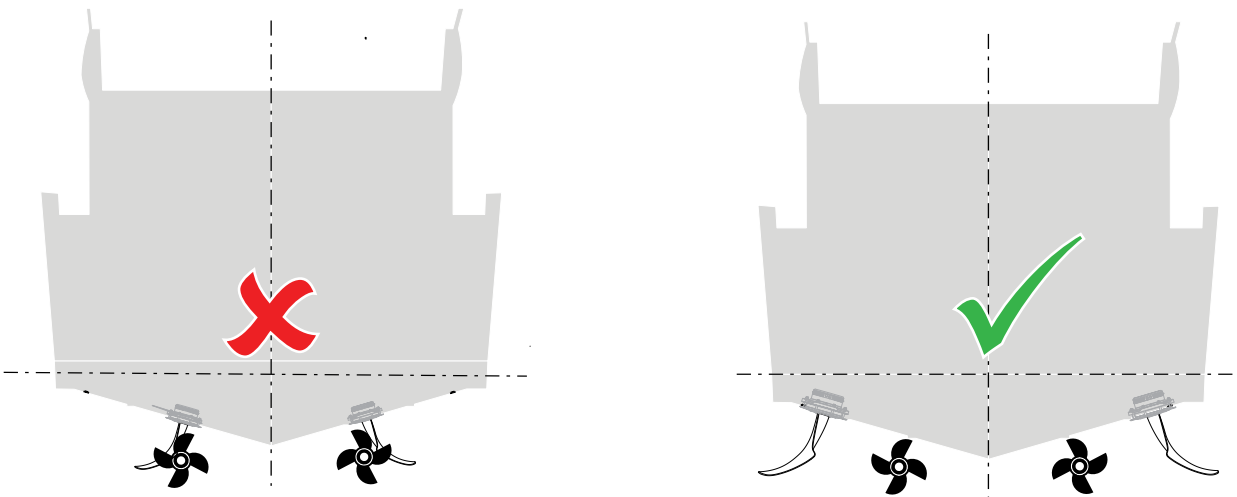

Fins should be placed as far outboard as possible, and NOT in-line with the propellers, to ensure avoiding possible disturbance of the water flow to the props which in the worst case can cause vibrations / cavitation.

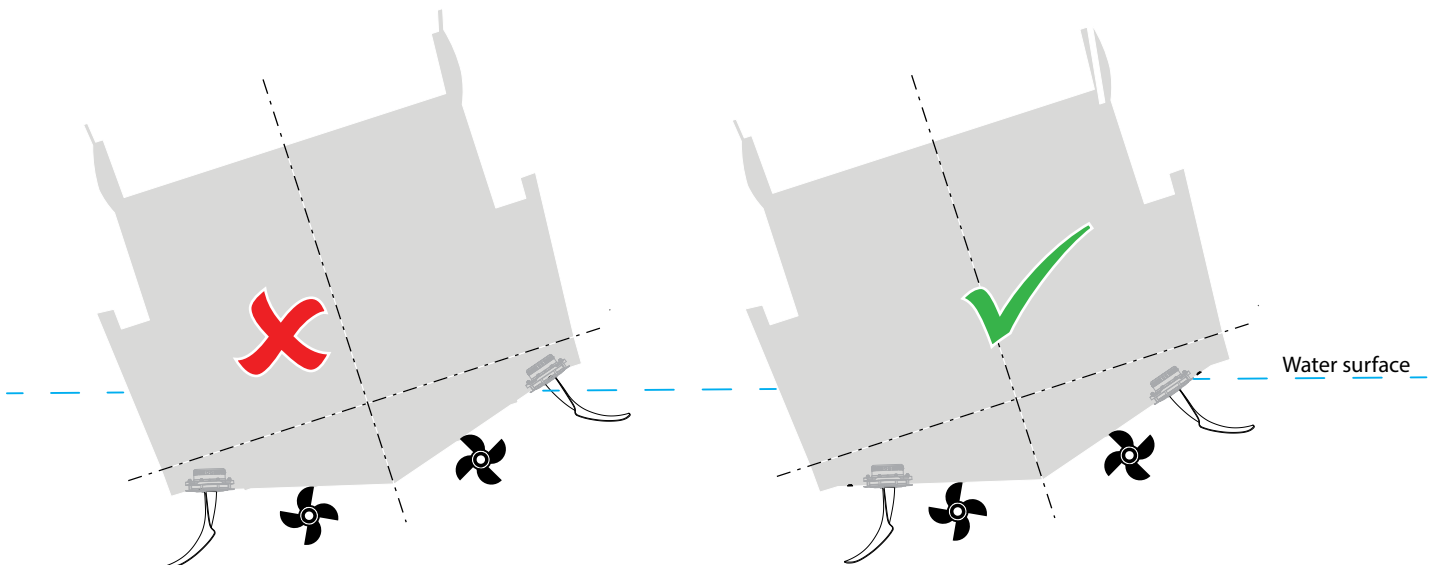

No part of the fin should be above water level during normal roll motion/under normal sea conditions.

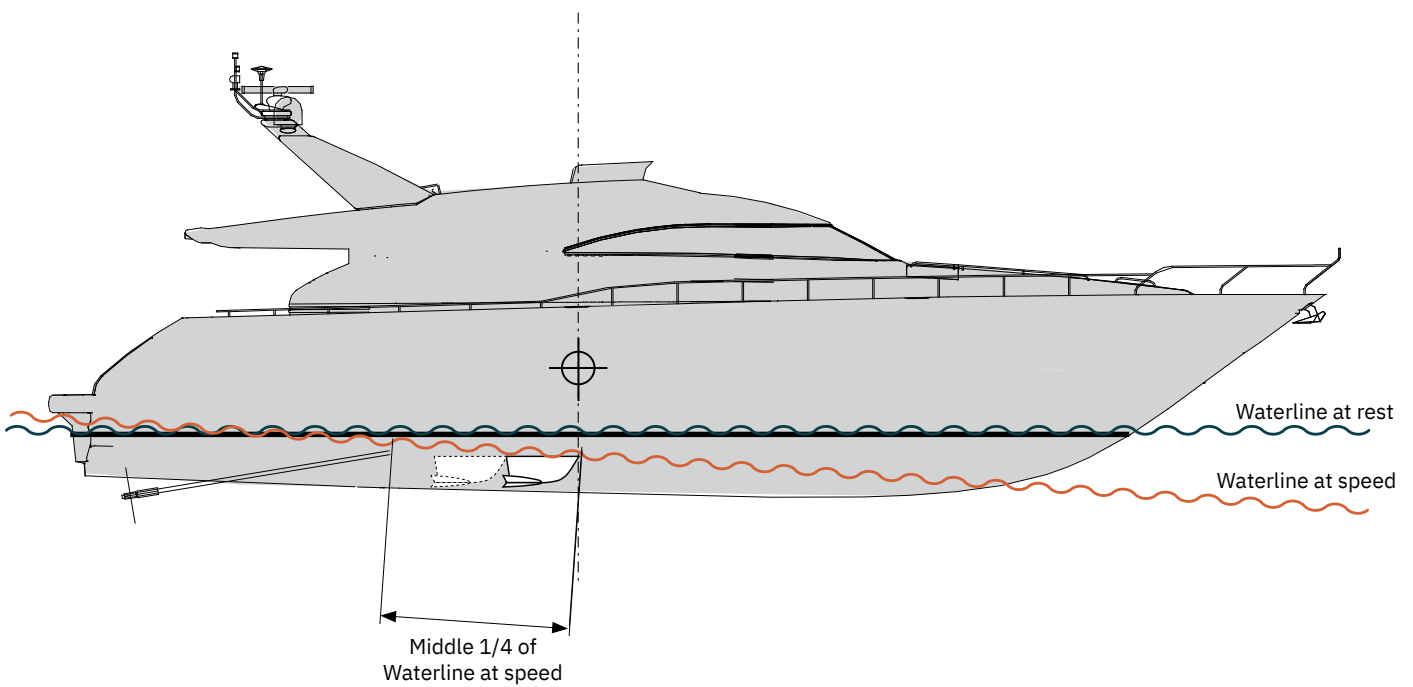
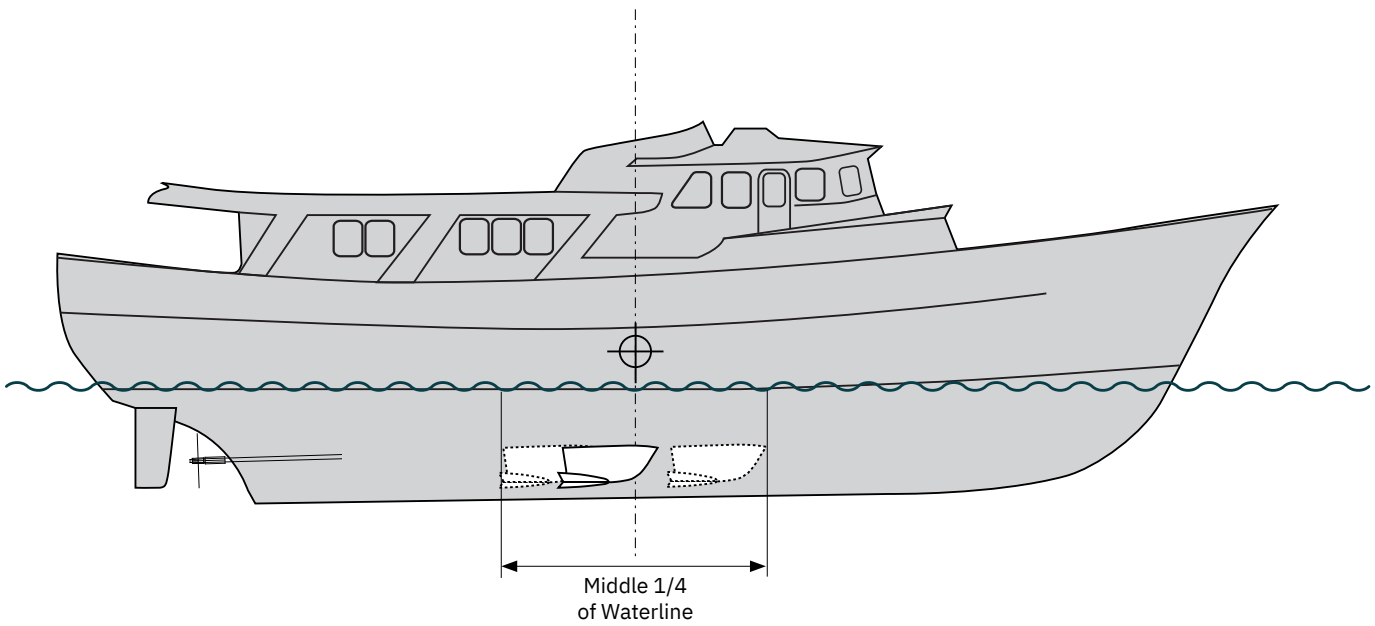

To avoid unwanted influences on the steering characteristics, the fins should be placed close to the vessel longitudinal centre of gravity (LCG)  
 - If unknown, this is usually a little aft of 50% of the waterline length.

For high speed vessels, the fins should be placed with trailing/leading edge within middle 1/4 of waterline length at speed and not in front of the LCG.

For vessels with top speed under 15 knots, fin may be placed within the middle 1/4 of waterline length.

**(NB: These are general guidelines and some hull types might allow for an installation position outside of this recommendation.)**



## Transversal fin positioning of Vector Fins™

With Vector fins™ it is a priority to push the fins as far outboard as possible to achieve the most leverage for the fins forces unlike standard fins.

Finding the best position for the fin and actuator positioning often is related to the inside configuration and space that is required for proper installation.

### General Rules:

–Push the actuators as far as possible outboard, keeping at least 22 degrees of outboard stroke as a minimum. It is also acceptable installing the fins further inboard if inside configuration/ access to inside parts of actuators is required. **(NB: Performance will be reduced slightly due to less leverage arm for the stabilizing force applied by the fins.)**

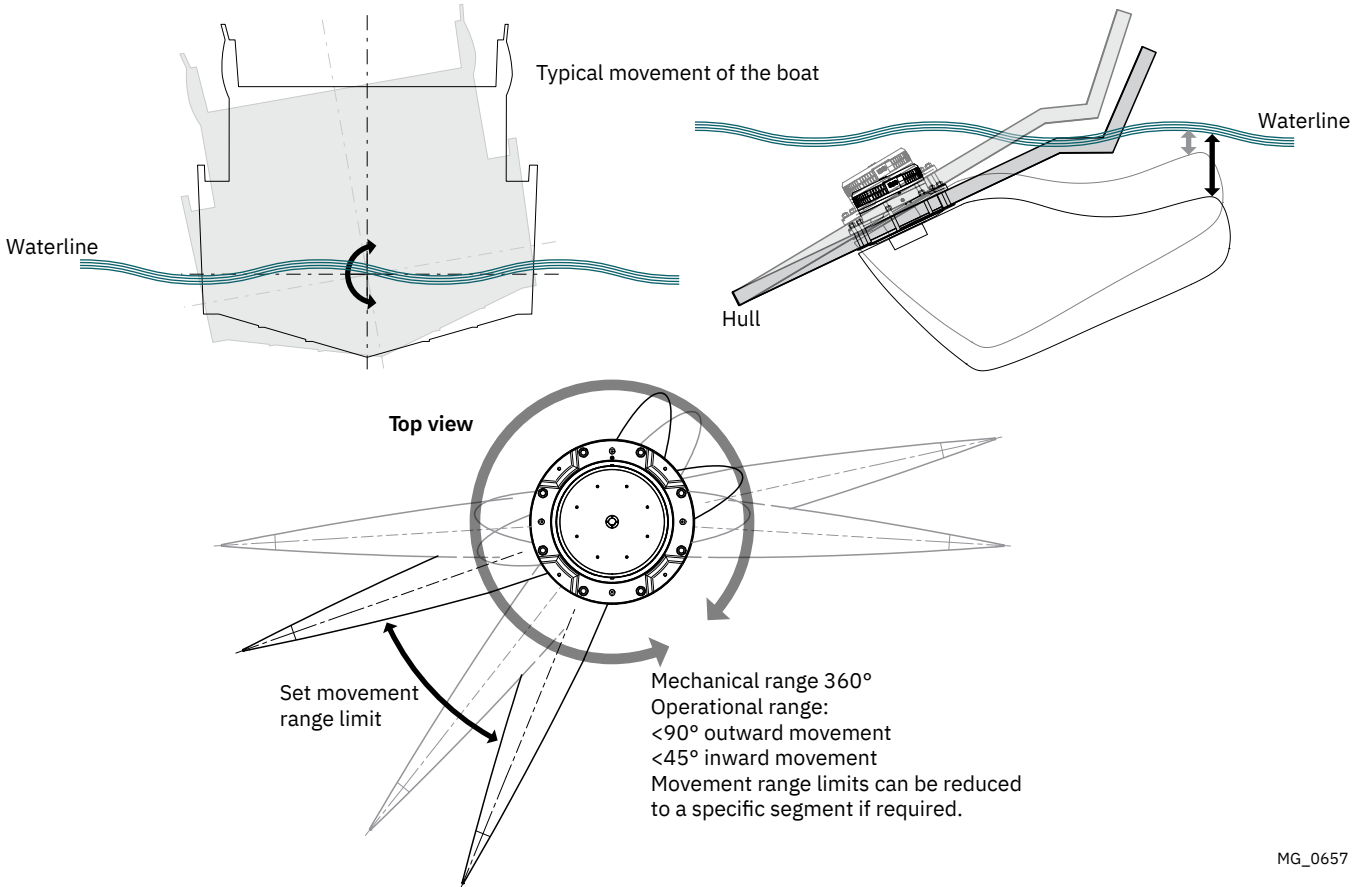

MG\_0657

All calculated values are normalised, determined by equilibrium considerations and also that various coefficients are inaccurate as hull design etc will affect the actual fin effect.  
 Dynamic effects such as jumps/impacts with waves, back flow closing of valve etc could further increase the hull/shaft loads. Therefore all dimensioning should account for this by using a safety factor.

Sleipner curved Vector Fin design comes with additional benefits in hull safety. Any impact with the ground will not only bend the shaft backwards and outward, allowing the fin to break away with less stress on the hull.

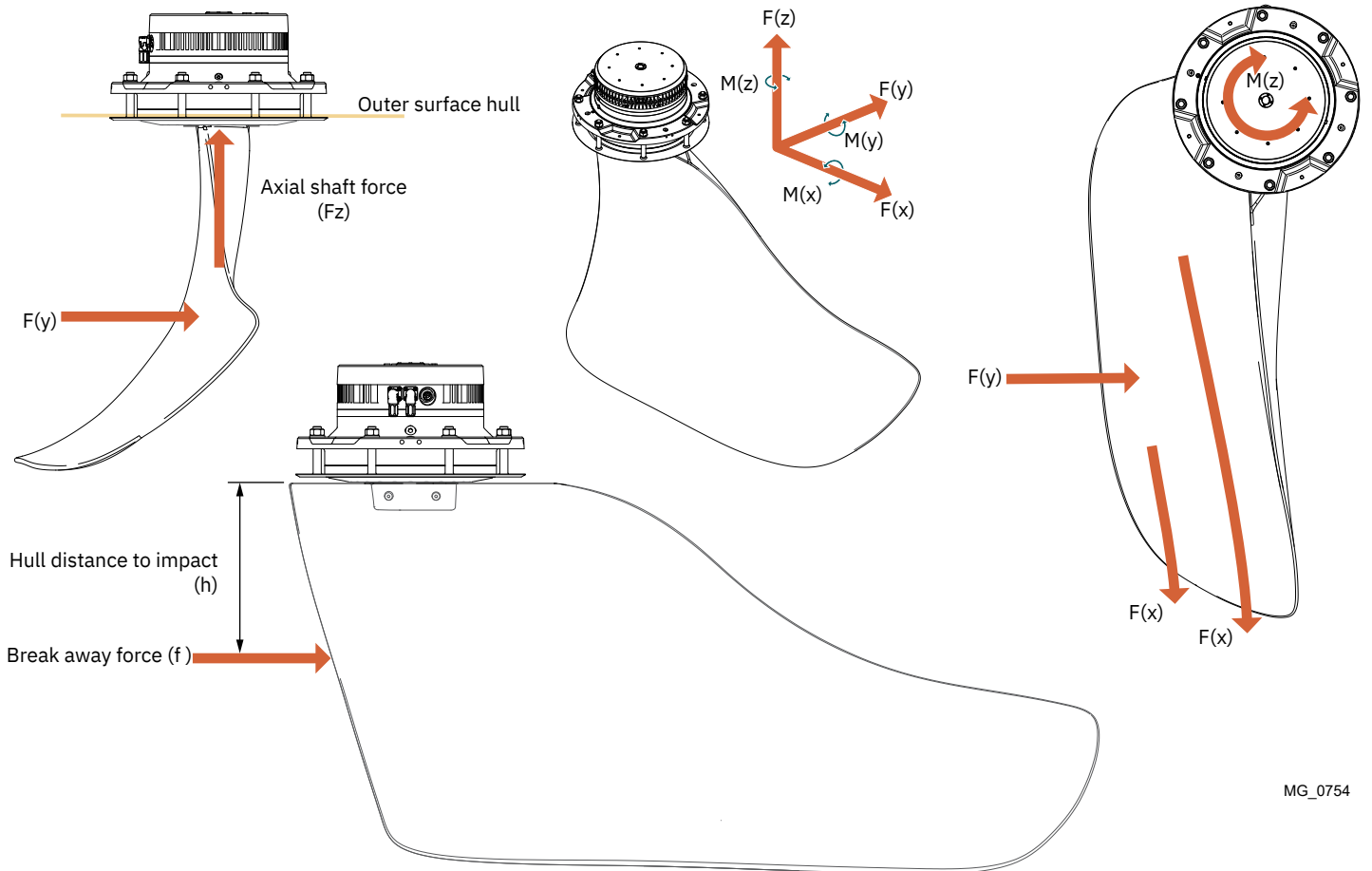

MG\_0754

SPS40E							
Structural requirements V3-9		Values to be considered individually				Break away impact force	
Speed	Max bending moment (kNm)	Mx (kNm)	My (kNm)	Mz (kNm)	Fz (kNm)	h (mm)	f (kN)
20	9.3	8.2	4.4	1.5	17.4	400	50
30	12,5	10,6	5,5	1,5	22	400	50

SPS40E							
Structural requirements V4-8		Values to be considered individually				Break away impact force	
Speed	Max bending moment (kNm)	Mx (kNm)	My (kNm)	Mz (kNm)	Fz (kNm)	h (mm)	f (kN)
20	14	13	4	1,5	16	400	50
30	18	17	5	1,5	24	400	50
35	20	18	6	1,5	26	400	50

SPS50E							
Structural requirements V4-12		Values to be considered individually				Break away impact force	
Speed	Max bending moment (kNm)	Mx (kNm)	My (kNm)	Mz (kNm)	Fz (kNm)	h (mm)	f (kN)
20	19	19	4,5	1,5	18	450	80
30	23	22	5,2	1,5	26	450	80
35	30	29	7	1,5	30	450	80

SPS50E							
Structural requirements V4-8HS		Values to be considered individually				Break away impact force	
Speed	Max bending moment (kNm)	Mx (kNm)	My (kNm)	Mz (kNm)	Fz (kNm)	h (mm)	f (kN)
20	14	13	4	1,5	16	400	50
30	18	17	5	1,5	24	400	50
35	20	18	6	1,5	26	400	50
40	25	24	7	1,5	34	400	50

# Actuator Components

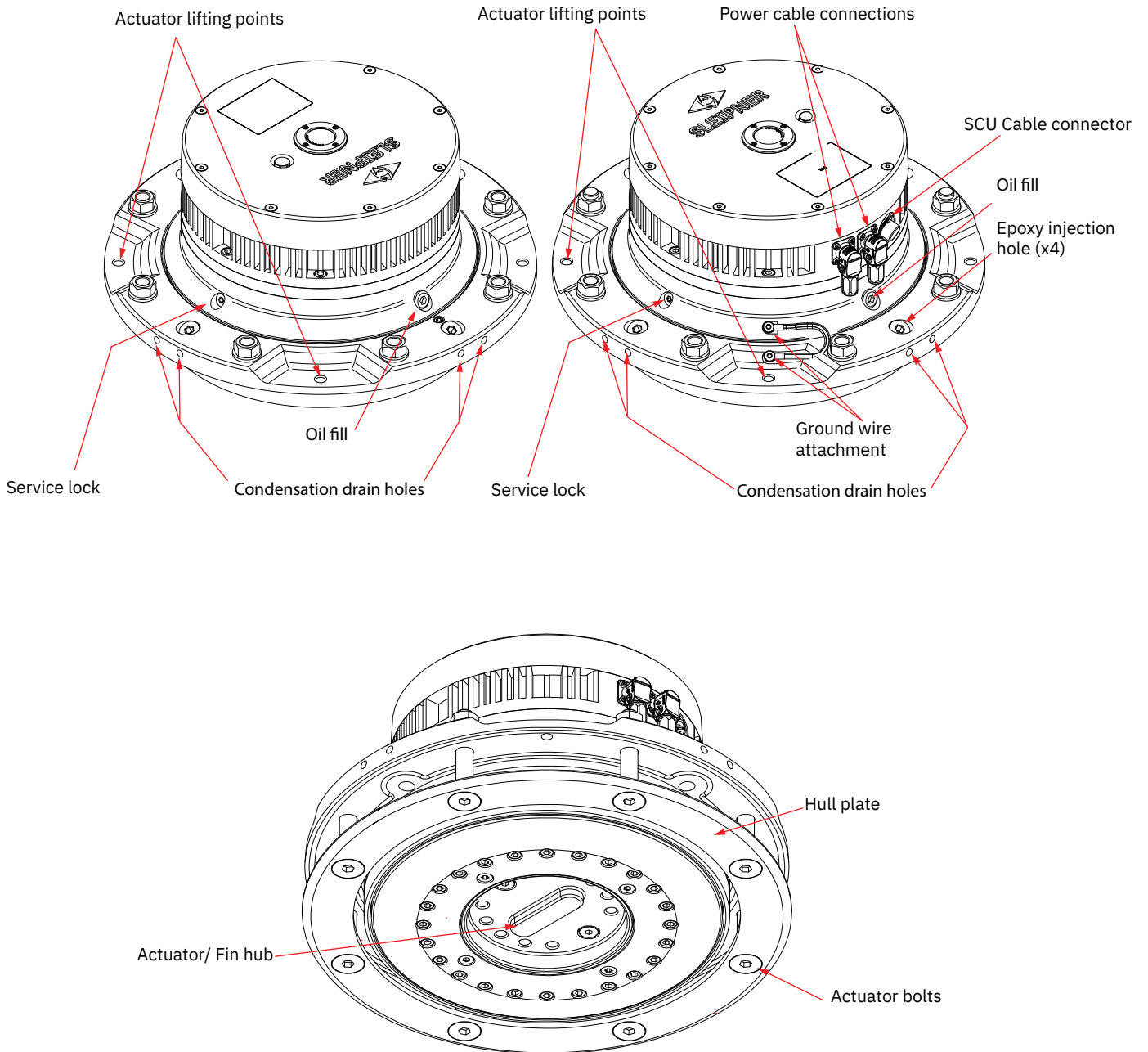

MG\_0752

! Please refer to the graphic for special considerations relating to your model !



**WARNING**

When modifying the hull to is important to seek recommendations from a naval architect. Details for Reinforcing/ strengthening the hull for the stabilizer installation must be in accordance with a naval ships architects recommendations.

Define the optimal position of the stabilizer fins.

1. Drill a pilot hole at the fin shaft centre line position externally through the yachts hull.
2. Using the pilot hole as centre line mark and cut hole from inside the boat using a suitable cutting Jig & tool.

Through Hole Dimensions	SPS40E		SPS50E	
	mm	inch	mm	inch
Minimum	348	13.7	369	14.5
Recommended	352	13.9	373	14.6
Maximum	360	14.2	381	15

3. Adjust the surrounding hull to the above thickness (Sealant included) and ensure that the internal and external surfaces are parallel and flat.

Hull Thickness	SPS40E		SPS50E	
	mm	inch	mm	inch
Minimum (Ensures secure sealing between the hull and actuator)	45	1.8	50	2
Recommended/ Target	50	2	55	2.2
Maximum (Avoids the risk of applying sealant between the fin hub and actuator)	52	2.05	57	2.2

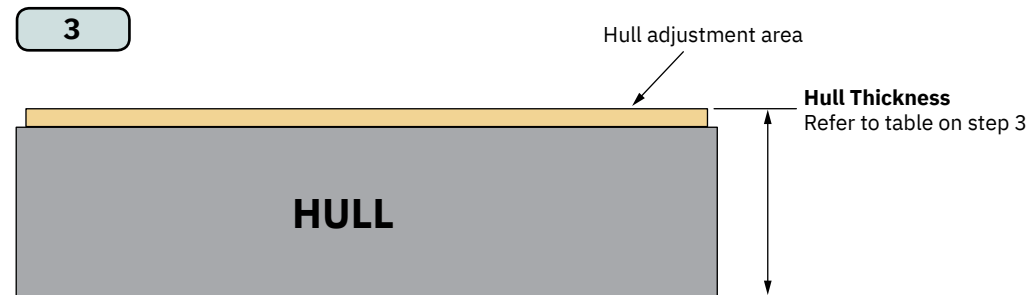
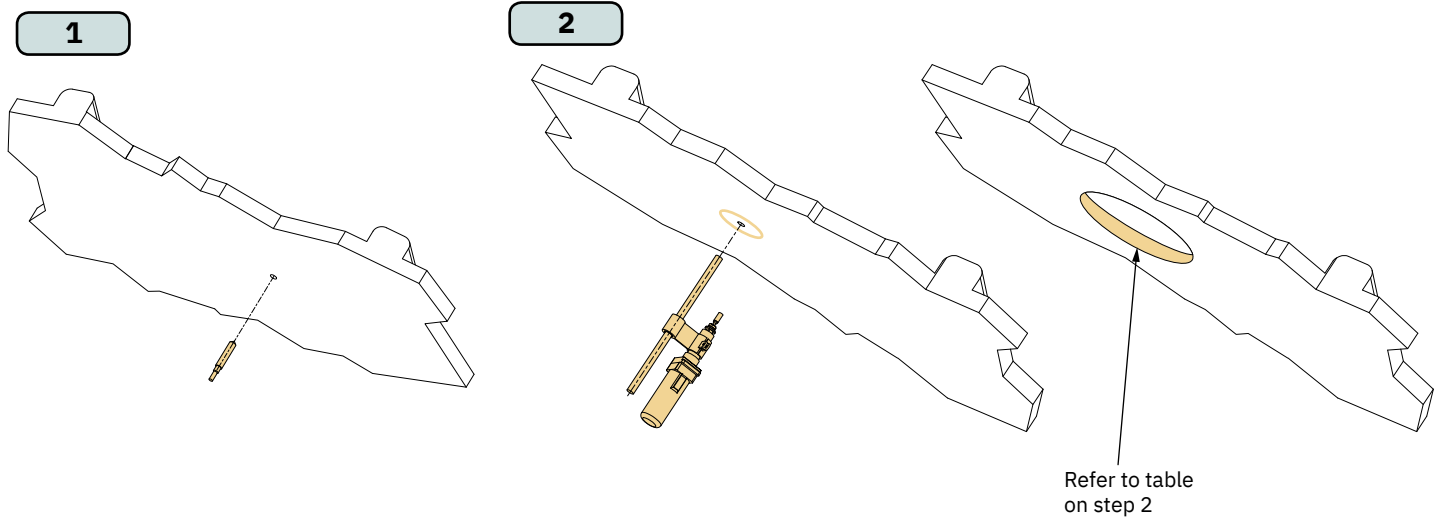

*! Please refer to the graphic for special considerations relating to your model !*

4. Mark the positions of the holes for the securing bolts. **(NB: Use the external hull plate as a template.)**

Dimension code	Dimension description	SPS40E		SPS50E	
		mm	inch	mm	inch
ØA	Hull plate external diameter	455	17.9	475.5	18.7
ØB	Hole positional diameter	400	15.7	421	16.6
ØC	Hull plate internal diameter	360	14.2	380.5	15
ØD	Hull plate hole diameter	19.5	0.76	19.5	0.76

5. Drill a pilot hole using the external hull plate as a guide. **(NB: Drill pilot hole from inside the hull.)**

6. Complete the drilling to the defined hole diameter required. **(NB: Drill final hole from outside the hull.)**

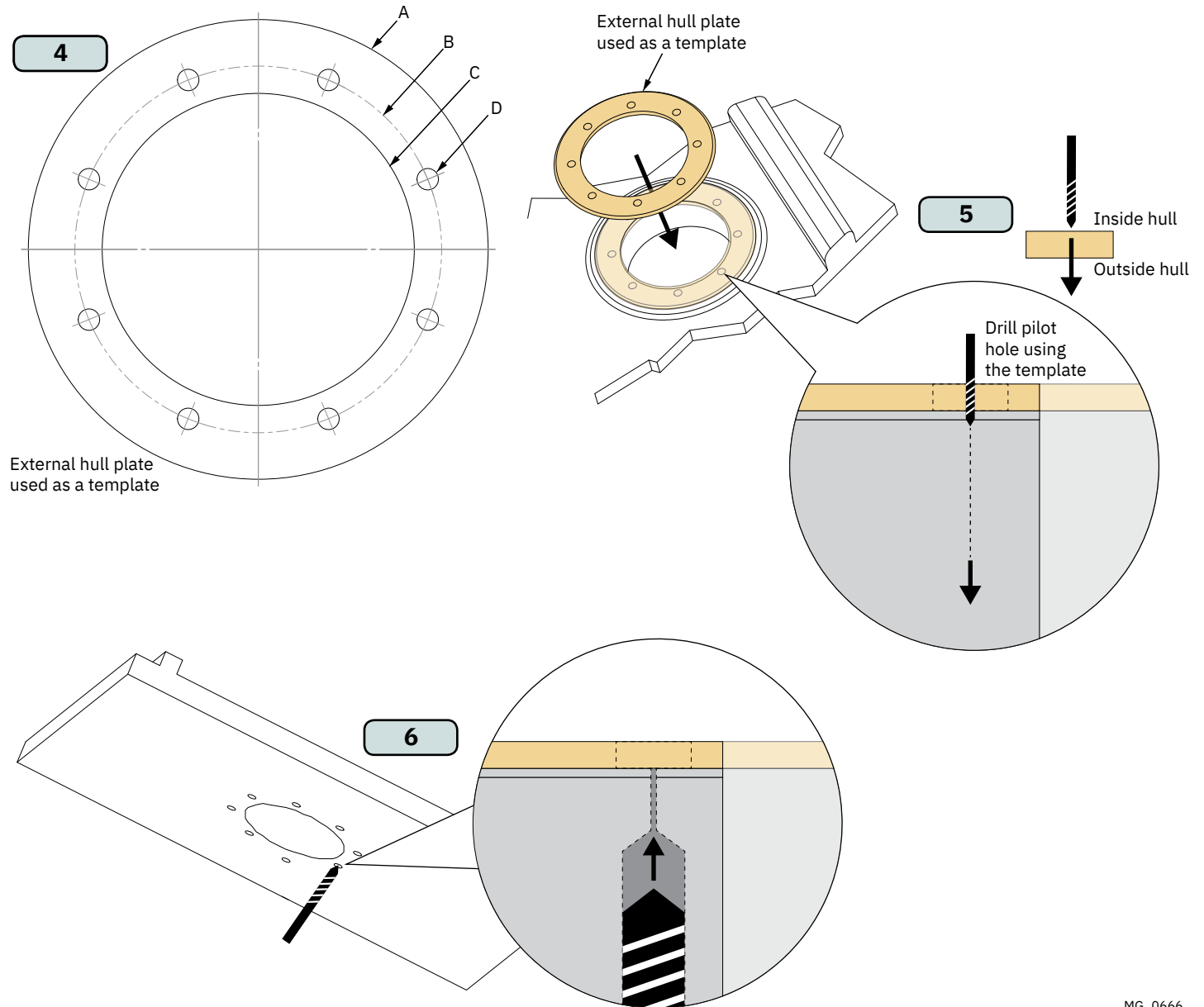

*! Please refer to the graphic for special considerations relating to your model !*

7. Countersunk all holes to allow space for bolt heads and sealant without damaging the hull.
8. At the area inside the vessel where the 4 epoxy injection ports are, create a chamfered edge. **(NB: The chamfer is to ensure an open area for the future injection of the epoxy compound).**

	a°	b
SPS40E	90°	20mm
SPS50E	90°	20mm

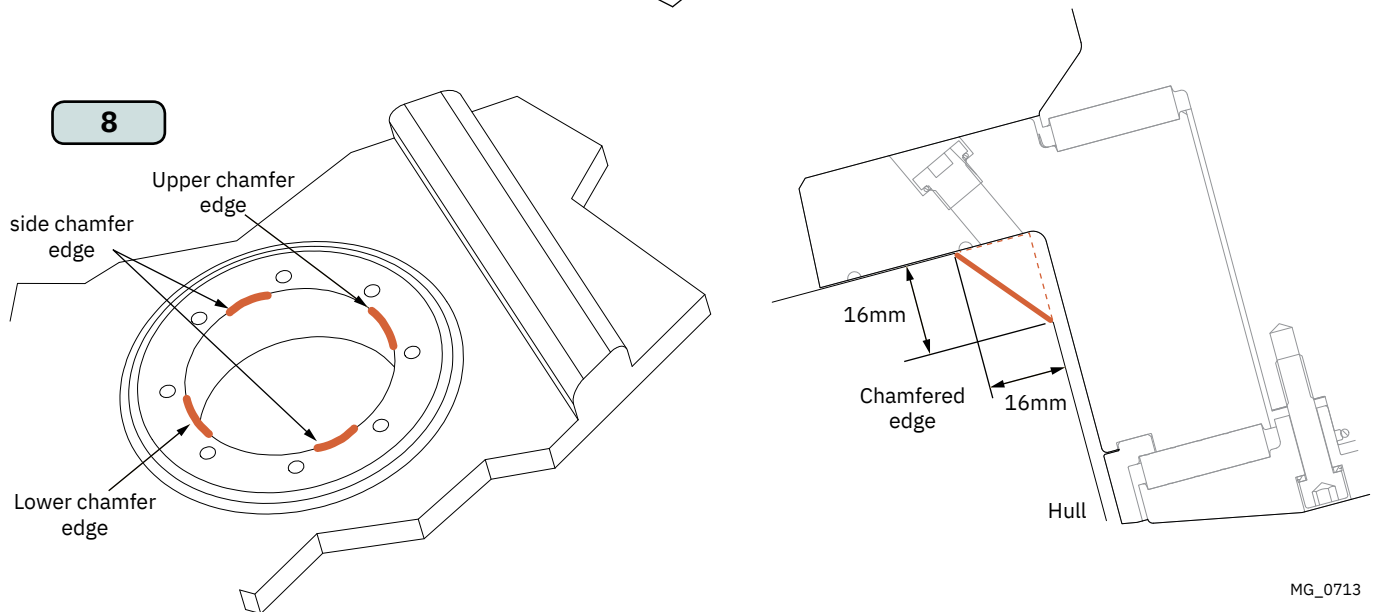
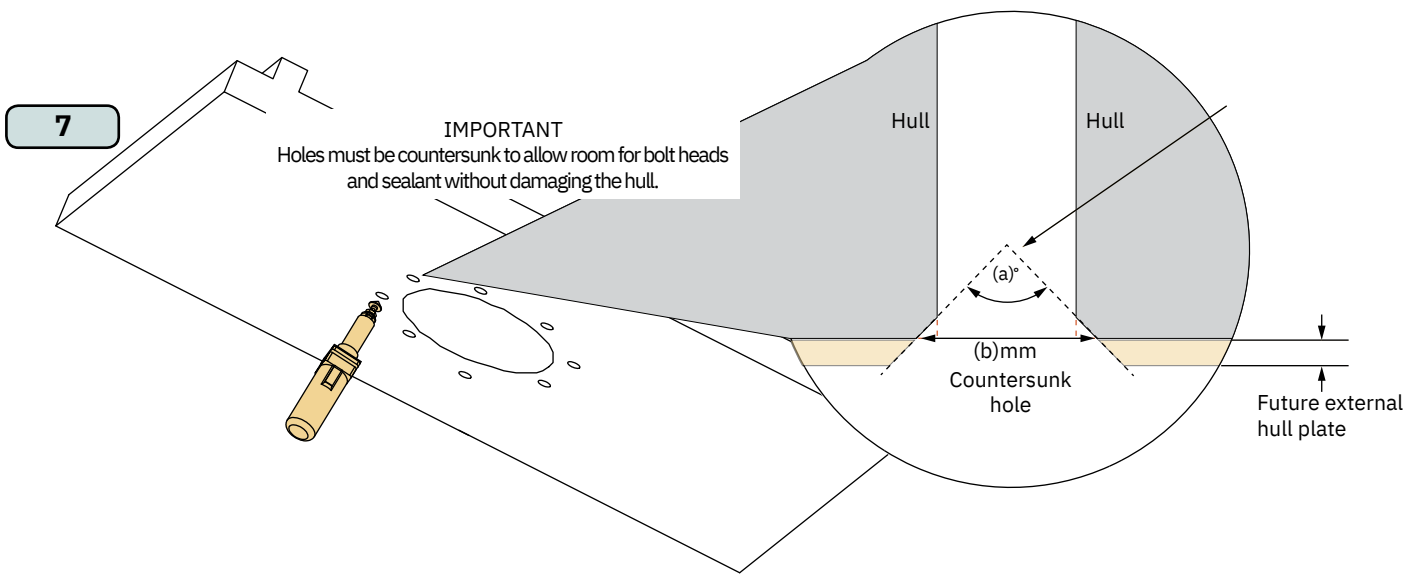

MG\_0713

! Please refer to the graphic for special considerations relating to your model !

## MOUNTING OF THE STABILIZER ACTUATOR ASSEMBLY

### NOTE:

- Steps 9-17 must be finalized within the cure time of the watertight sealant being used. Step 18 can be initiated only after the sealant is cured.
9. Apply watertight sealant to the mating surface of the hull and the actuator inside the boat. Do not apply watertight sealant around inner chamfered edges. (NB: Sealant must be compatible with hull material. A naval architect/Boat builder must confirm this.)
  10. Lower the Stabilizer Actuator Assembly into the hulls actuator hole. (NB: Use the actuator lifting eyes to thread lifting slings combined with a mechanical support to assist in a controlled lowering of the actuator.)

### IMPORTANT NOTES:

- Ensure that at least one of the oil drainage holes are at the lowest point of the installation angle. (Reference 1).
- Ensure that the condensation drain holes (Reference 2) are not covered by sealant or other material. Condensation on the actuator will flow into the void between the motor and hull assemblies, and must drain out through these holes. The condensation drain holes must always be at the actuators lowest point.

The condensation drain holes are always positioned straight above the oil drain hole, and there are four sets of oil- and condensation drain holes with a mutual offset of 90 degrees between the sets.



### WARNING

Use a mechanical support to lower the actuator into position, as an actuator can weigh approx 300kg. Attach two safety slings through the bolt hole and remove just before lowering the actuator into its final position. Ensure at least one of the four oil drainage holes is at the lowest of the installation angle.

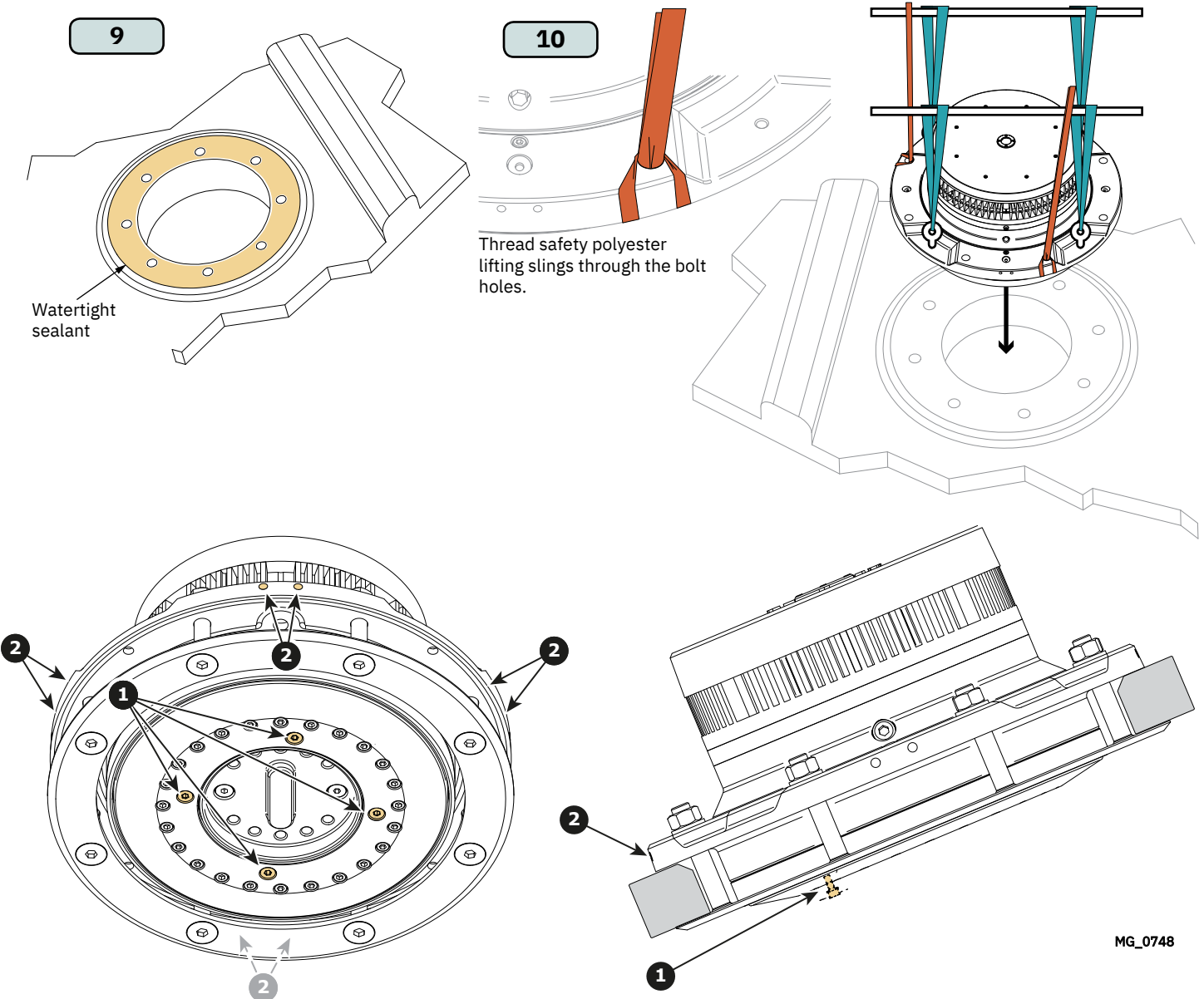

MG\_0748



! Please refer to the graphic for special considerations relating to your model !

## MOUNTING OF THE STABILIZER ACTUATOR ASSEMBLY

11. Ensure the actuator shaft core sits concentric to the hole. Ensure the 4 epoxy injection ports are over the chamfered edge and not obstructed. **(NB: Remove the injection port plugs to inspect the actuator sits over the chamfered edge and is clear from obstruction for the injection process.)**

**(NB: Do not throw away injection plugs as they are needed later during installation!)**

Scan the QR code for an injection procedure video.

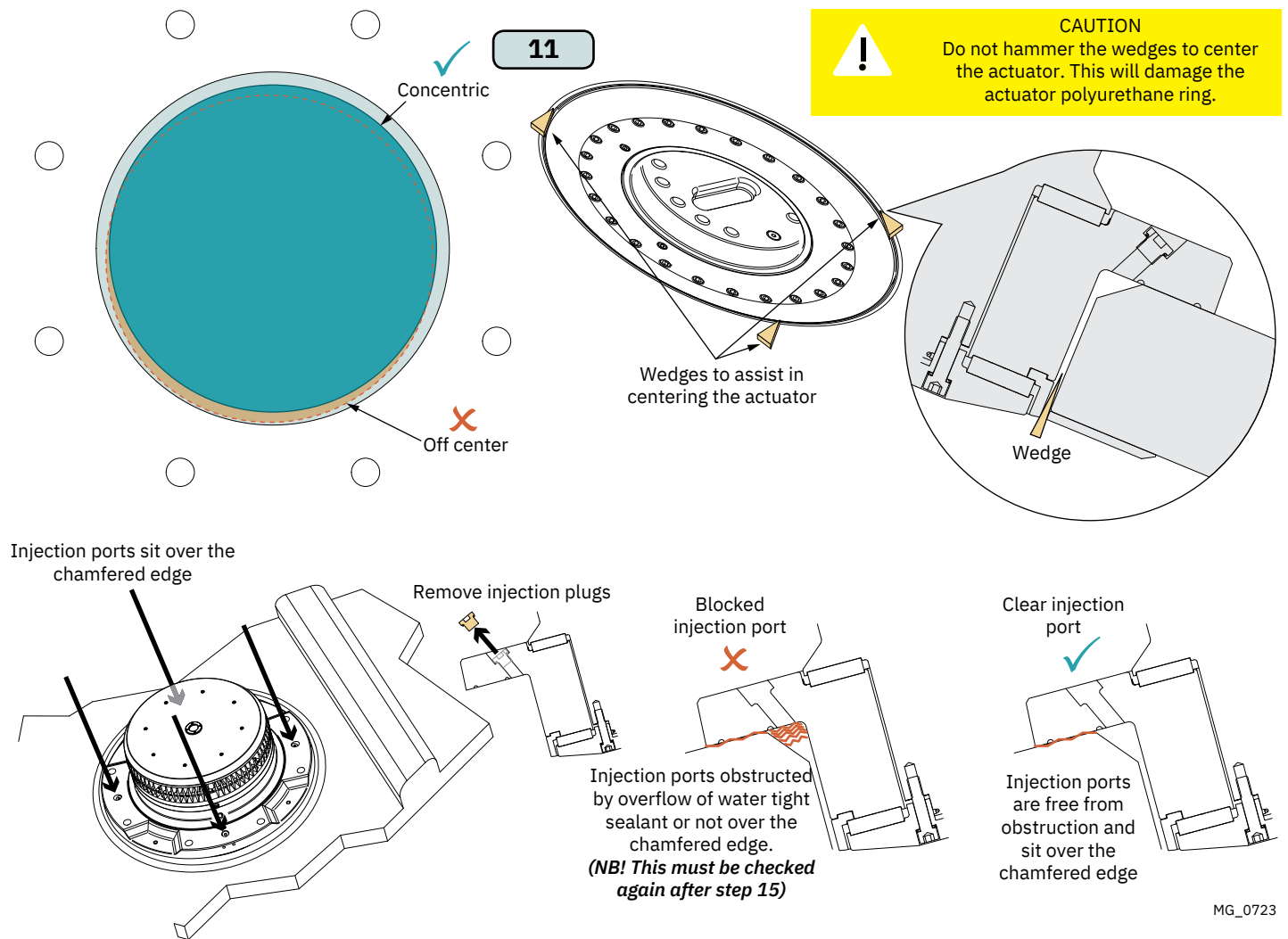

MG\_0723

*! Please refer to the graphic for special considerations relating to your model !*

## MOUNTING OF THE STABILIZER ACTUATOR ASSEMBLY

12. Apply watertight sealant to the Hull plate, can also be applied directly on the hull. Additional apply sealant on the bolt countersunk area to achieve proper sealing between bolt head, Hull plate and to the plate securing bolts.
13. Place the Hull plate over the Stabilizer shaft & onto the external hull mounting surface.
14. Insert actuator bolts with watertight sealant to the Hull plate.
15. Tighten & torque load the securing bolt nuts with washers in two stages following the defined number order to avoid misalignment.  
 Stage 1: Fasten each bolt to the defined tightening vaule and order.  
 Stage 2: Fasten each bolt to the defined tightening vaule and order.

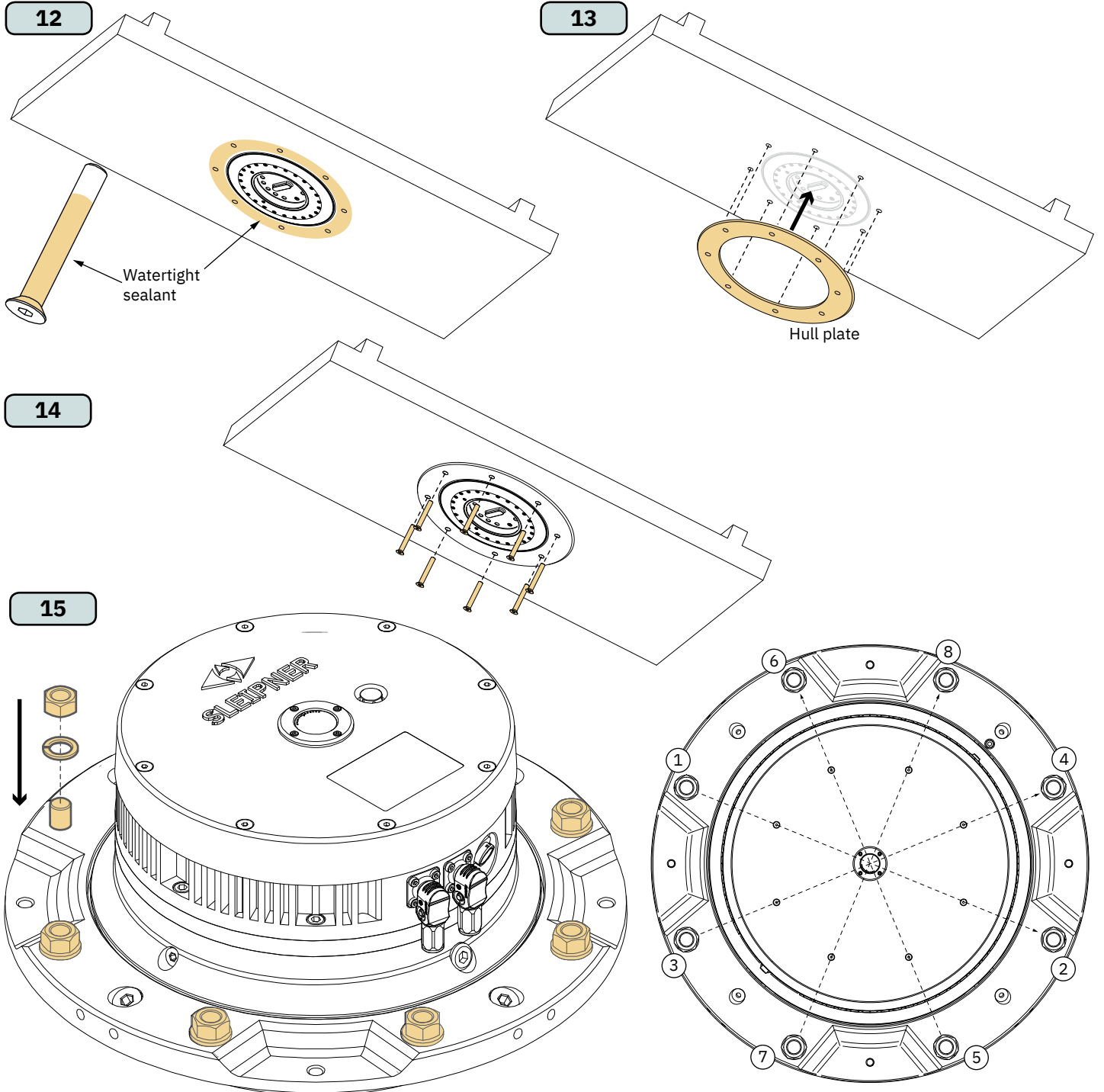

**CAUTION**  
 To prevent galling, add grease to the nut threads and fasten slowly.

Tighten	SPS40E	SPS50E
Stage 1	30Nm	30Nm
Stage 2	130Nm	130Nm

Fasten bolts diagonally to avoid misalignment

! Please refer to the graphic for special considerations relating to your model !

16. Clean away any overflowed watertight sealant if necessary and seal the lower gap with a neoprene cord. Push the neoprene cord 25mm past the actuator polyurethane ring. **(NB: The polyurethane ring is identifiable as a red ring on the lower actuator. Sleiþner supply 2 different flexible rings in delivery. Choose the ring that achieves the closest to 30% compression)**
17. Fill the lower void with polyurethane sealant or similar to create a water tight seal between the hull and the actuator. Sealant must be completely cured before proceeding to the next step.

**IMPORTANT NOTICE: Ensure that the polyurethane sealant is not allowed to enter the gap between the polyurethane ring and the external seal plate, by covering the gap during the process.**

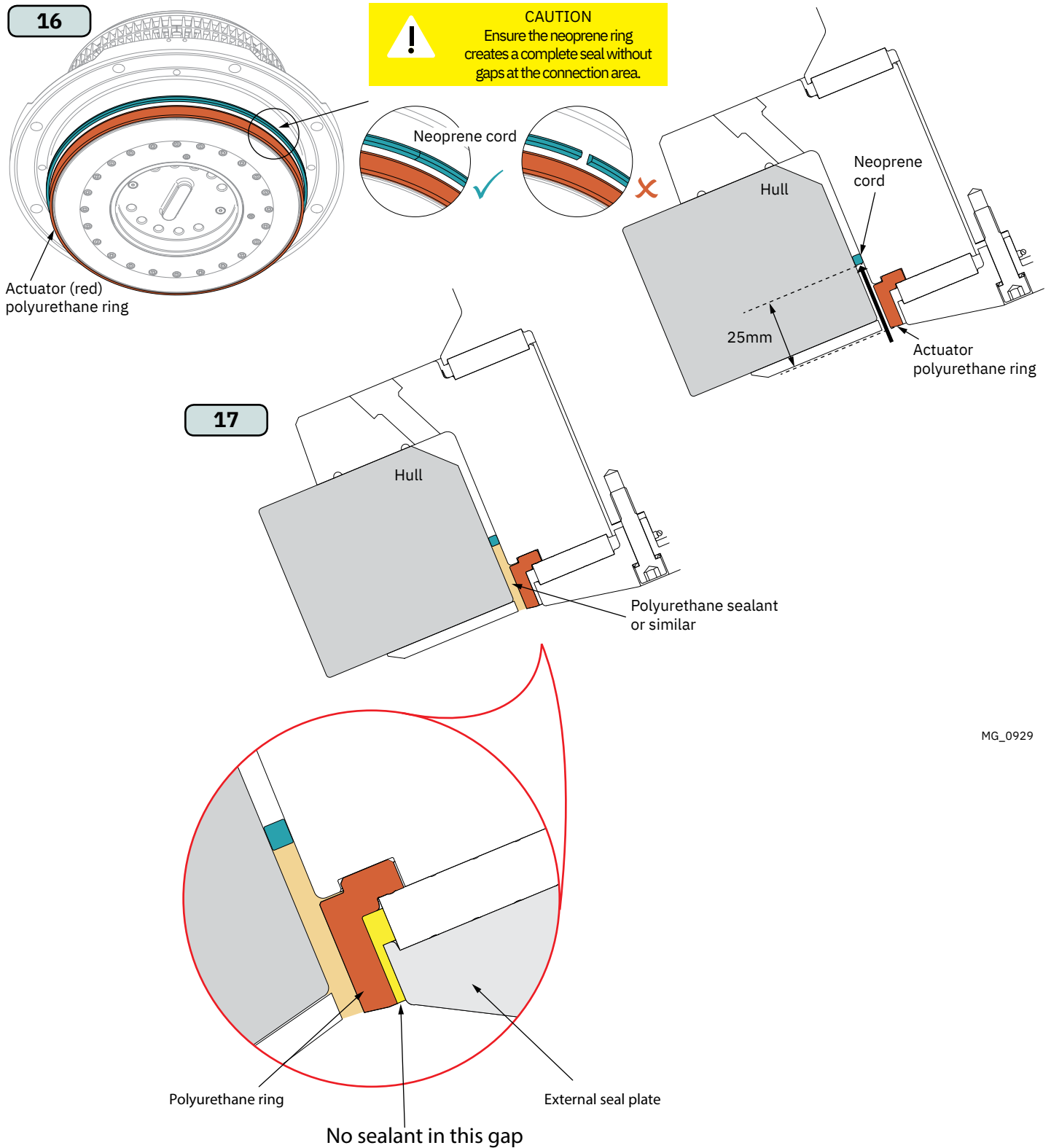

MG\_0929

! Please refer to the graphic for special considerations relating to your model !

**IMPORTANT NOTICE:** Ensure that the polyurethane sealant is not allowed to enter the gap between the polyurethane ring and the external seal plate, by covering the gap during the process.

18. Remove the blind plugs, insert the injection plugs with thread tape added and attach the hoses to the injection plugs. Inject the epoxy filler through the lower injection holes on the actuator base plate. Inject epoxy until it flows out of the upper injection hole. **(NB: Commonly the actuator is installed on a slight angle. The lower injection port is defined as lowest port on the base plate.)**
  - a. Press the filler into the lowest point.
  - b. When clean epoxy filler without bubbles comes out of drain port 1 and 2, close the drain ports.
  - c. Continue filling until a small reservoir forms in the last (top) drain to allow flow back during the cure time process. **(NB: Recommend hose length is 500mm for the upper injection hose to allow flow back during the curing process.)**
19. After the epoxy filler compound has hardened, remove all four hoses and insert blind plugs.

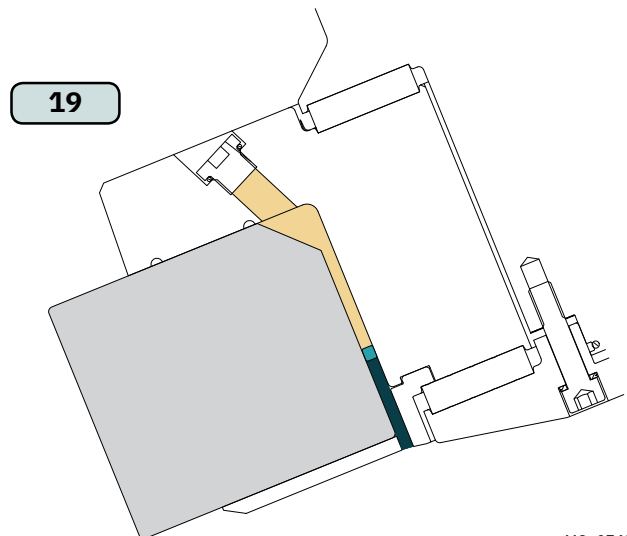
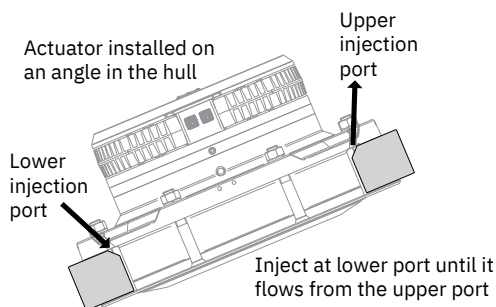
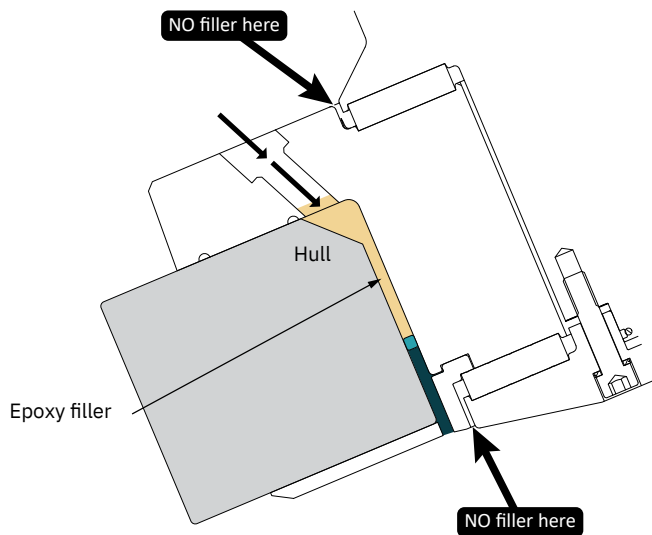
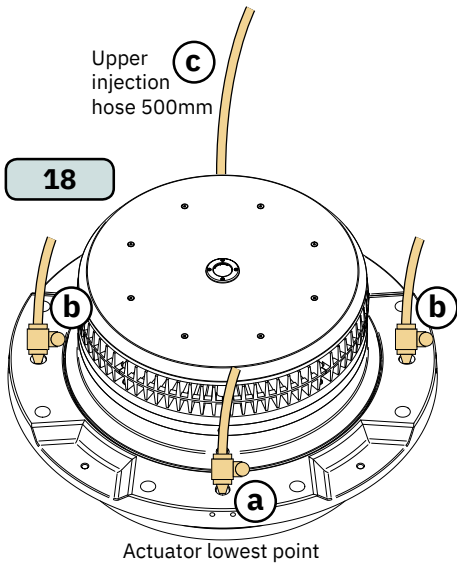

**WARNING**  
 After injection is complete. Remove all remaining compound containers from the vessel due to fire risk. (exotherm curing process)

MG\_0743

## 1. Plan the installation

The installation should be planned according to available cable length and placement recommendations for the different components. A system overview is shown in the Wiring Diagram chapter.

### SPS40E Power cables

Connect actuator power cables and fuse according to the table below. See chapter “Power connector assembly” for preparing the cables

Actuator model	Supply Voltage	Supply current peak	Supply current max average	Recommended wire size	Recommended fuse rating
SPS40E	+24V/48V	150A/75A	60A/30A	25mm <sup>2</sup> /16mm <sup>2</sup>	100A/50A
SPS50E	+24V/48V	150A/75A	60A/30A	25mm <sup>2</sup> /16mm <sup>2</sup>	100A/50A

## 2. Connect Actuator ground wire

Connect a ground wire from the vessel's main bonding/ anode system to each actuator. The wire must be connected to both the positions indicated. **(Reference 1)**. Use M6x10 bolts.

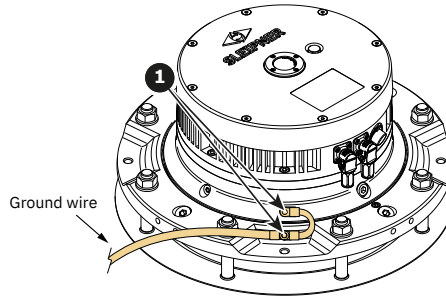

MG\_0749

## 3. Stabilizer Control Unit (SCU)

The motion sensor used by the stabilisation algorithm is located inside the SCU. It is important to mount the SCU to a stable surface perpendicular to the keel, preferably on a bulkhead and as central as possible in the boat. A typical location is the forward or aftward engine room bulkhead. During system configuration it is specified in the control panel if the SCU is mounted facing bow or stern. The SCU must be installed with the connectors facing down and clearance for cables bend radius. The cable to be used between the SCU and the actuator is available in several predefined lengths, with a maximum length of 30-meters. The location of the SCU must be selected so that it is in reach of the actuator with one of the available cable lengths.

MC\_0731

Connect the supplied SCU Power Cable between connector X1 on SCU and a 24V DC supply protected with a 15A fuse. It is recommended to have a dedicated switch on the 24V supply to the SCU to enable a complete shut-down of the system.

Connect an S-Link spur cable between connector X2 on SCU and a T-Connector on the S-Link back bone cable.

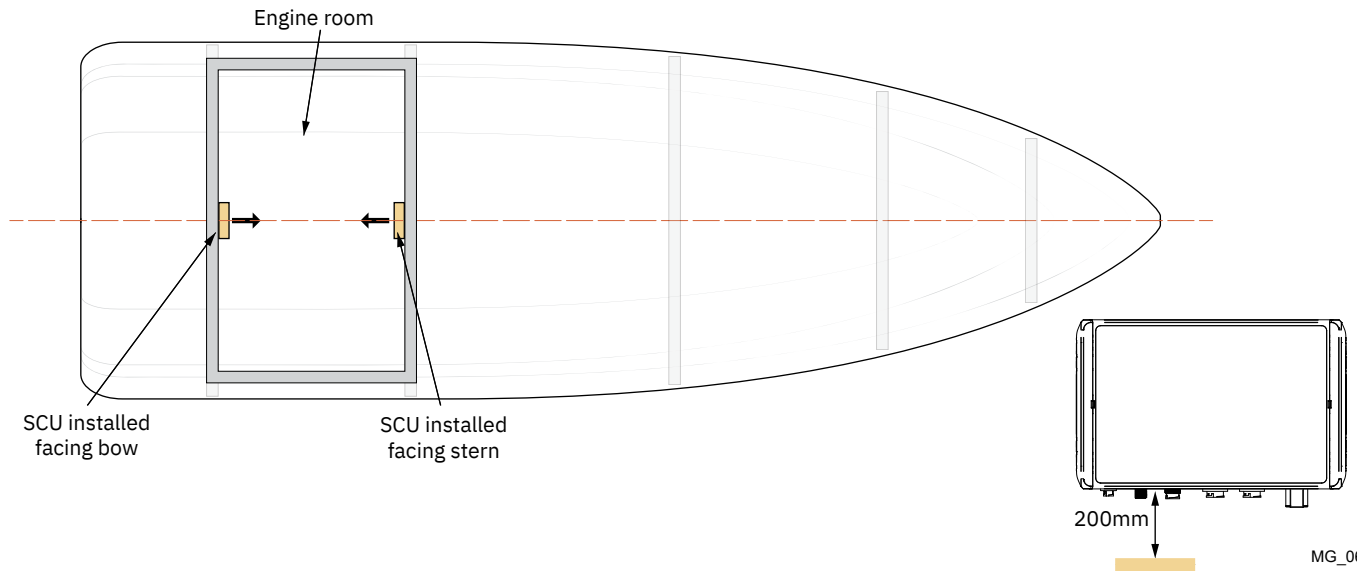

MG\_0673

## SCU Cable Installation

MC\_0718

### SCU cable

Connect the actuator on starboard side to connector X5 on SCU and connect actuator on port side to connector X6 on SCU.

Cables for connection of stabilizer system are available in the following standard lengths shown in the table:

Order number	Length
151370-040	4m
151370-070	7m
151370-100	10m
151370-150	15m
151370-200	20m
151370-250	25m
151370-300	30m

The actuator power connectors are delivered as a kit, and must be assembled and crimped to the power cables.

**Note that there are two different assemblies for the 16mm<sup>2</sup> and 25mm<sup>2</sup> cables.**

The parts and procedure is described on the following pages.

**Connector parts:**

1. Connector body
2. Barrel (For 16mm<sup>2</sup> cable only).
3. Sleeve (For 16mm<sup>2</sup> cable only).
4. Sleeve (For 25mm<sup>2</sup> cable only).
5. End nut

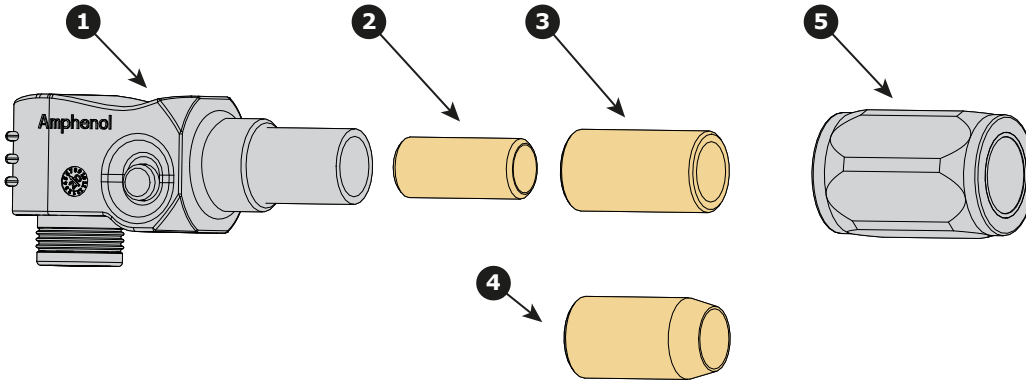

MG\_0960

## Assemble the connector and 16mm<sup>2</sup> cable

- Remove the cable insulation with a length of 18 +/-1 mm from the cable end (**Reference 1**).
- Thread the end nut (**Reference 2**) and 16mm<sup>2</sup> sleeve (**Reference 3**) onto the cable.
- Thread the barrel (**Reference 4**) onto the uninsulated part of the cable
- Thread the connector onto the cable end with the barrel (**Reference 5**).
- Crimp the connector (**Reference 6**) with a hexagonal crimp tool.
- Slide the sleeve against the connector, and enter the end nut to the threads on the connector, and tighten (**Reference 7**).

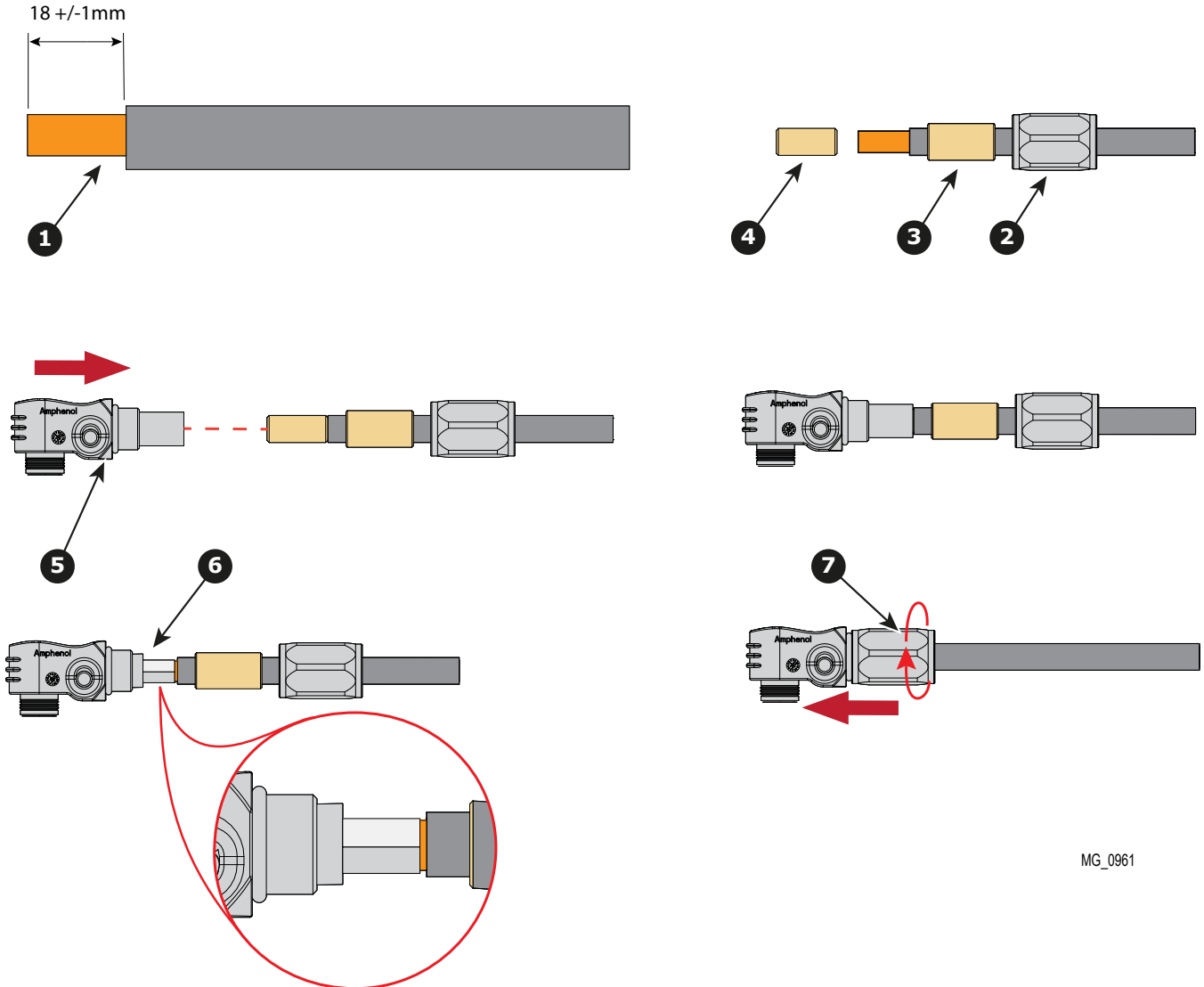

MG\_0961

## Assemble the connector and 25mm<sup>2</sup> cable

- Remove the cable insulation with a length of 18 +/-1 mm from the cable end (**Reference 1**).
- Thread the end nut (**Reference 2**) and 25mm<sup>2</sup> sleeve (**Reference 3**) onto the cable.
- Thread the connector onto the cable end (**Reference 4**).
- Crimp the connector (**Reference 5**) with a hexagonal crimp tool.
- Slide the sleeve against the connector, and enter the end nut to the threads on the connector, and tighten (**Reference 6**).

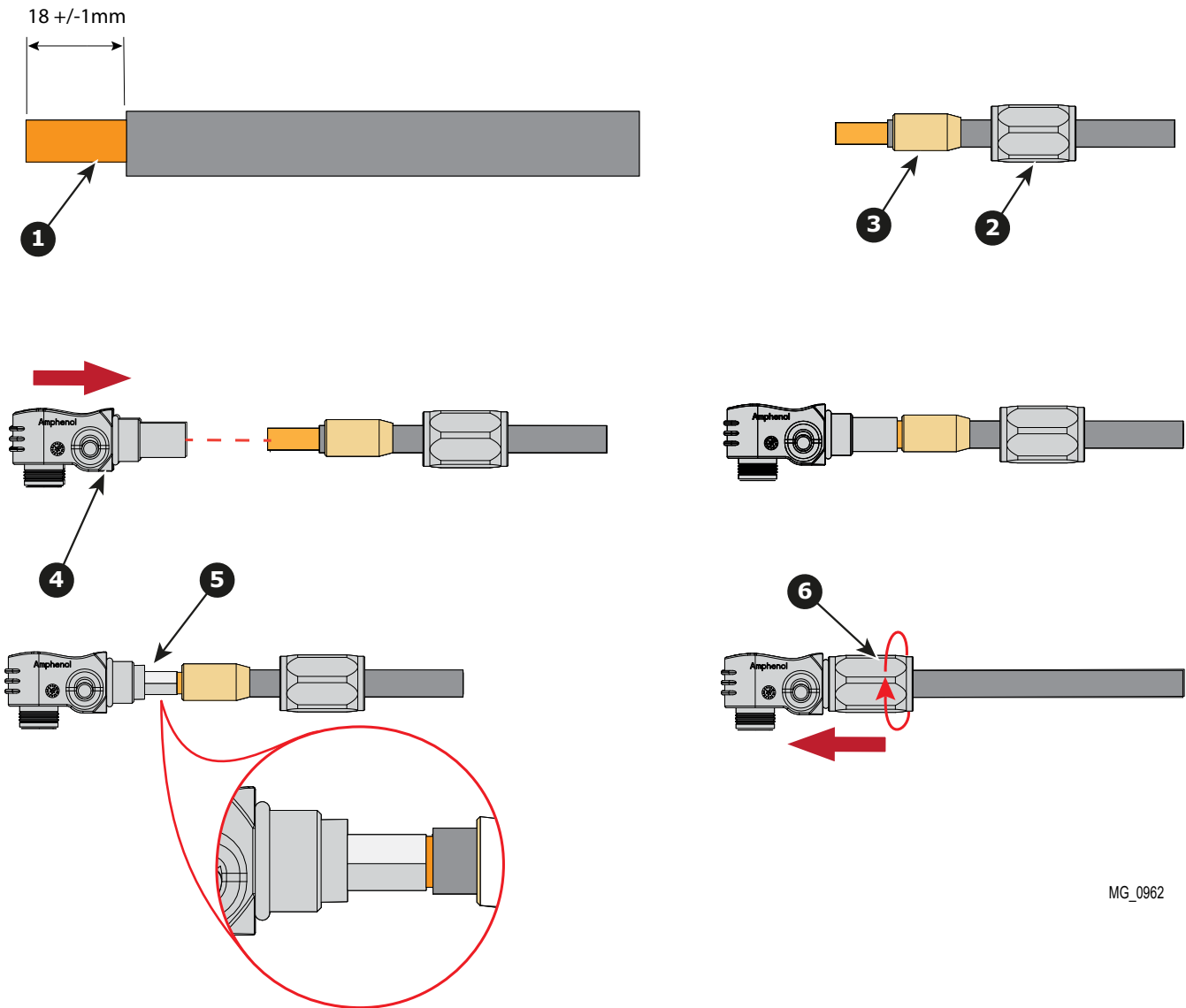



**1. Control panel**

Install control panel according to instructions in the Installation Guide accompanying the control panel.

**2. GPS receiver**

SCU requires speed data from a GPS to operate the stabilizers. GPS signal must be interfaced through the S-Link Gateway (GW-1).

A GPS can be interfaced either through the NMEA 0183- or the NME 2000 port on GW-1. See GW-1 user manual, document number 3057, for detailed information on connection of GPS and installation.

If using NMEA 2000 GPS input, ensure that signal is available at all times when stabilizer operation is required.

If using NMEA 0183 it is recommended to power the GPS from GW-1. If GPS is installed with dedicated power supply the GPS must always be powered when S-Link power is turned on.

Connect GW-1 to S-Link as shown in the Wiring Diagram chapter.

The GPS antenna should be installed where it can get a clear view of the sky and not be in the shadow of obstructions.

**3. Reverse detection**

To ensure proper operation and avoid damage the fins must be put in centre position when the vessel transmission is set in reverse for astern movement. The SCU offers three solutions for reverse detection. Ensure to select SCU-KIT order number according to desired reverse detection solution.

Revers Detection	SCU order number	Comment
NMEA 2000	SCU-KIT-2F-NMEA	GW-1 included for NMEA 2000 and GPS integration.
Pressure switches	SCU-KIT-2F-TD	Two pressure switches for Twin Disk transmission included. GW-1 included for GPS integration.
	SCU-KIT-2F-ZF	Two pressure switches for ZF transmission included. GW-1 included for GPS integration.
Reverse solenoid interface	SCU-KIT-2F-SO	Reversing Solenoid Interface included. GW-1 included for GPS integration.

**NMEA 2000**

If main engine transmission PGN127493 is available on NMEA 2000, this bus can be connected to GW-1 and the PGN made available for the SCU.

**Pressure switches**

For some types of engines, pressure sensors can be installed on the main engine transmission. The drive direction can be monitored by detecting the pressure level in the gearbox control. Sensor port position can vary between different transmission models. Please contact engine supplier for instructions.

Both switches shall be connected in series and connect to connector X3 on SCU by using the supplied Reverse Detection Cable. An open switch is interpreted as transmission is put in reverse.

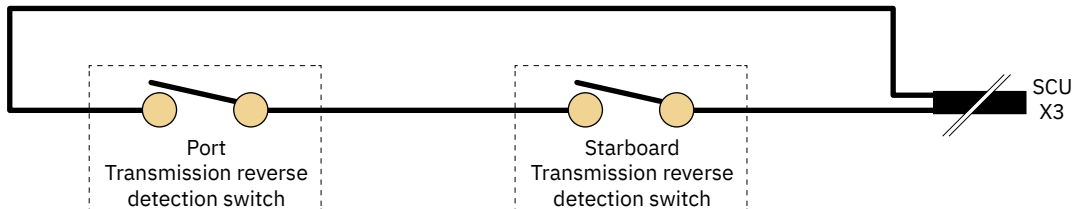

MG\_0687

**Reverse solenoid interface**

For vessels not having available ports for pressure switches, connecting to 24V transmission solenoid signals could be an option. The solenoid signals must be connected to the Reversing Solenoid Interface box and the Reverse Detection Cable shall be connected between connector X3 on SCU and the Reversing Solenoid Interface box.

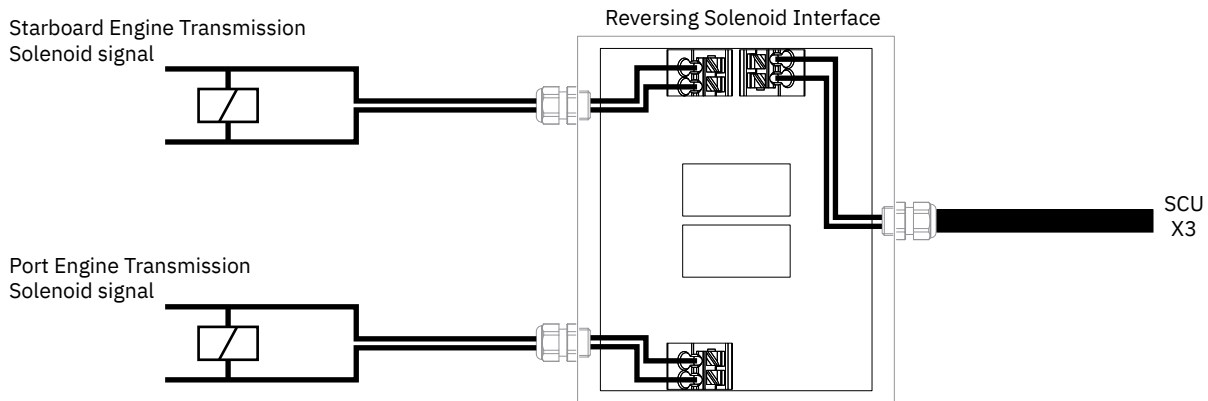

MG\_0685

**4. S-Link**

See the S-Link System Description chapter for detailed information on the installation of the S-Link Power cable, END Terminator and additional S-Link components.

S-Link is a CAN-based control system used for communication between Sleipner products installed on a vessel. The system uses BACKBONE Cables as a common power and communication bus with separate SPUR Cables to each connected unit. Only one S-Link POWER cable shall be connected to the BACKBONE Cable. Units with low power consumption are powered directly from the S-Link bus.

**Main advantages of S-Link system:**

- Compact and waterproof plugs.
- BACKBONE and SPUR Cables have different colour coding and keying to ensure correct and easy installation. BACKBONE Cables have blue connectors and SPUR Cables have green connectors.
- Different cable lengths and BACKBONE Extenders make the system scalable and flexible to install.

**Installation of S-Link cables:**

Select appropriate cables to keep the length of BACKBONE- and SPUR Cables to a minimum. In case of planned installation with total BACKBONE Cable length exceeding 100 meters please consult your local distributor. The S-Link cables should be properly fastened when installed to avoid sharp bend radius, cable chafing and undesired strain on connectors. Locking mechanism on connectors must be fully closed. To ensure long lifetime, cables, T-Connectors and Extenders should not be located so that they are permanently immersed in water or other fluids. It is recommended to install cables in such a way that water and condensation do not flow along the cables into the connectors. This can be done for example by introducing a u-shape bend before the cable enters the product connector.

Ideally, the POWER Cable should be connected to the middle of the BACKBONE bus to ensure an equal voltage drop at both ends of the BACKBONE Cable. The yellow and black wire in the POWER Cable shall be connected to GND and the red wire connected to +12VDC or +24VDC.

To reduce the risk of interference, avoid routing the S-Link cables close to equipment such as radio transmitters, antennas or high voltage cables. The backbone must be terminated at each end with the END Terminator.

SPUR cables can be left unterminated to prepare for the installation of future additional equipment. In such cases, ensure to protect open connectors from water and moisture to avoid corrosion in the connectors.

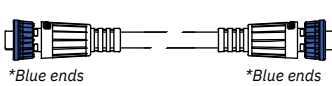

**BACKBONE Cable**

Forms the communication and power bus throughout a vessel. Available in different standard lengths.

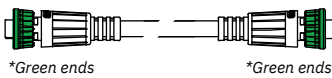

**SPUR Cable**

Used to connect S-Link compliant products to the backbone cable. One SPUR Cable must be used for each connected component, with no exceptions. Recommended to be as short as practically possible. Available in different standard lengths.



**POWER Cable**

Required in all installations for connection of BACKBONE Cable to a power supply and should be protected with a 2A fuse.

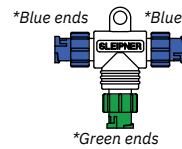

**T-Connector**

Used for connection of SPUR or POWER Cable to the BACKBONE Cable. One T-Connector for each connected cable.

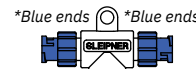

**BACKBONE Extender**

Connects two BACKBONE Cables to extend the length.

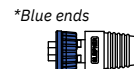

**END Terminator**

Must be one at each end of the BACKBONE bus.

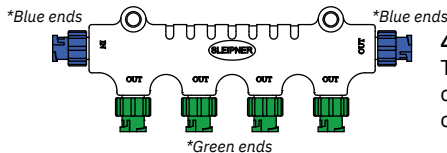

**4-Port T-Connector**

The 4-PORT T-connector allows multiple SPUR Cables to be connected. The 4-PORT T-connector comes with two sealing caps to protect unused ports.

**S-Link installation example**

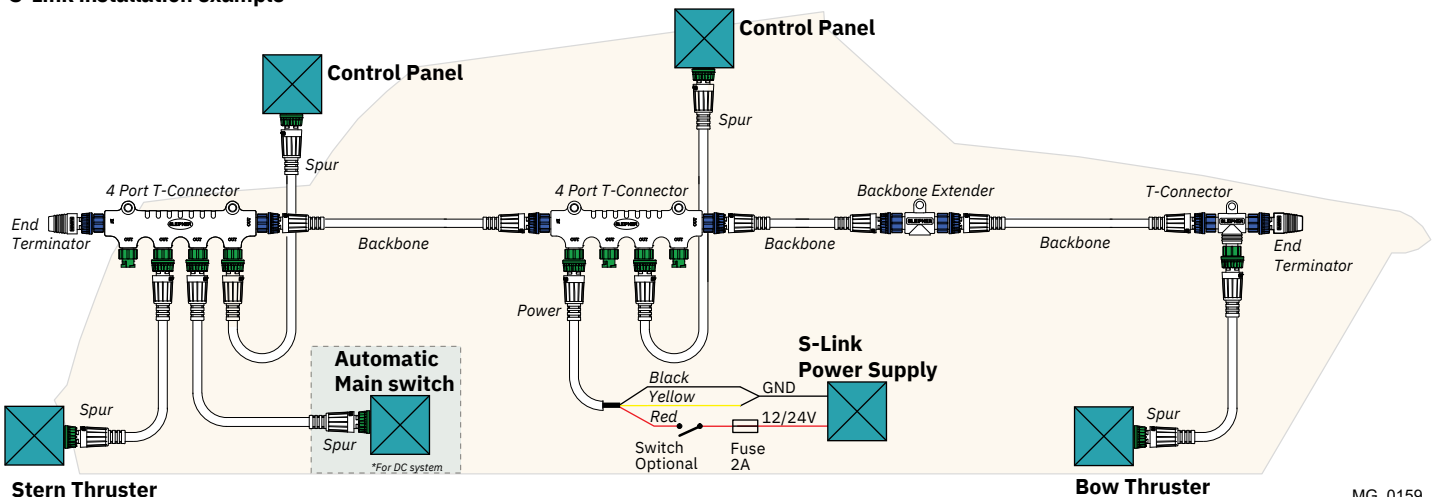

# Wiring Diagram

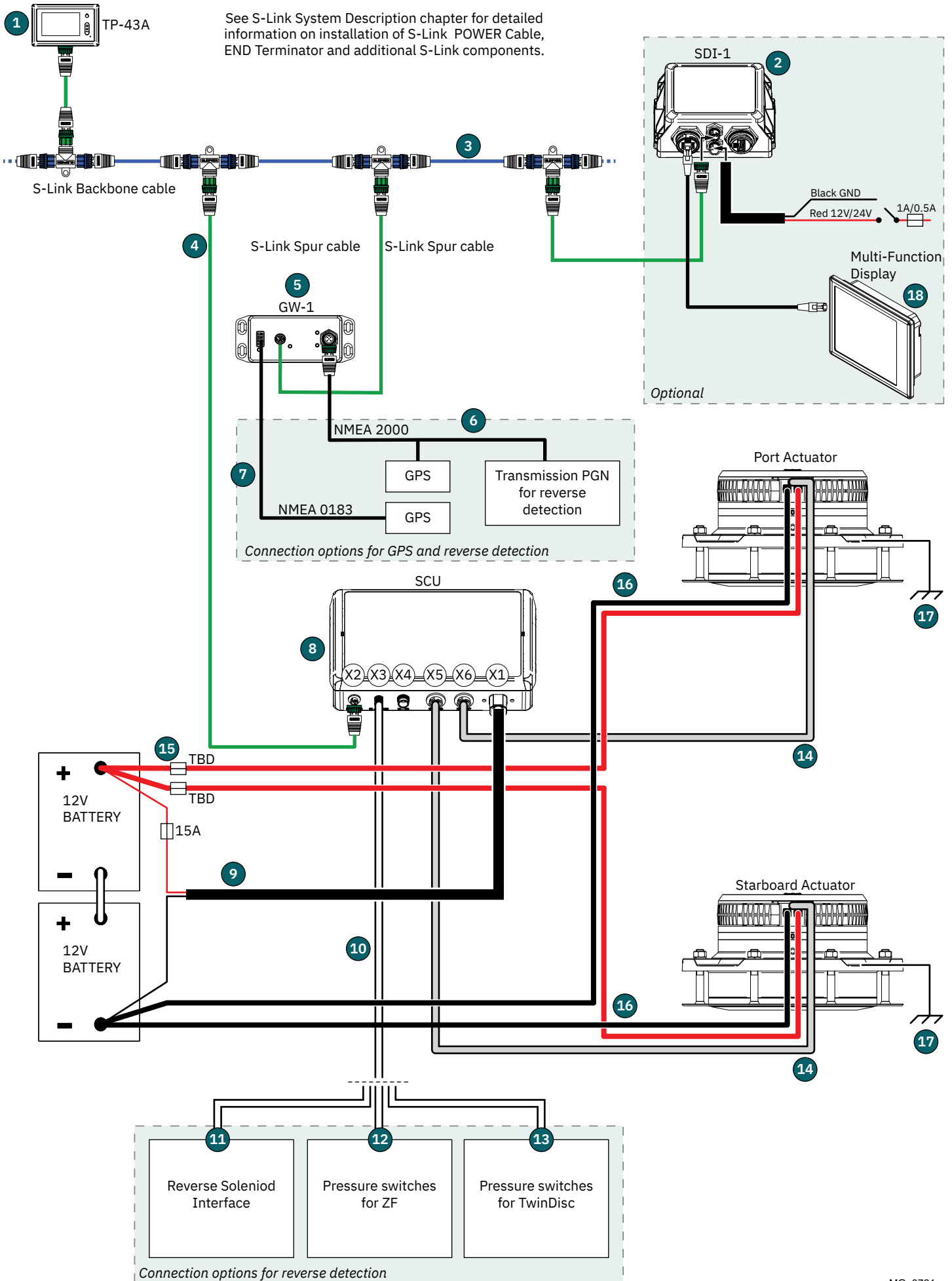

Reference Number	Item Number	Description
1	TP-43A	<b>Stabilizer control panel.</b> Included in all SCU-kits
2	SDI-1	<b>S-Link Display Interface.</b> Optional. Can be used for monitoring and configuration of thrusters and stabilizer
3	<b>S-Link Backbone cable</b>	<b>Available in different lengths</b>
	6 1320-0,2M	S-Link™ backbone control cable 0,2m
	6 1320-2M	S-Link™ backbone control cable 2m
	6 1320-4M	S-Link™ backbone control cable 4m
	6 1320-7M	S-Link™ backbone control cable 7m
	6 1320-10M	S-Link™ backbone control cable 10m
	6 1320-15M	S-Link™ backbone control cable 15m
	6 1320-20M	S-Link™ backbone control cable 20m
4	<b>S-Link Spur cable</b>	<b>Available in different lengths</b>
	6 1321-0,4M	S-Link™ spur control cable 0,4m
	6 1321-1M	S-Link™ spur control cable 1m
	6 1321-3M	S-Link™ spur control cable 3m
	6 1321-5M	S-Link™ spur control cable 5m
	S-Link	Other available S-Link components
	6 1328	S-Link™ spur power cable 2,5m
	6 1322	S-Link™ backbone extender
	6 1326	S-Link™ T-connector
	6 1403	S-Link™ 4-Port T-connector
	6 1327	S-Link™ terminator
5	GW-1	<b>S-Link™ gateway</b> Included in all SCU-kits
6	NMEA 2000 Network	<b>Not supplied by Sleipner</b> Used for GPS connection and/or reverse detection by NMEA engine control.
7	321714	<b>GPS-receiver for S-Link™ Gateway</b> NMEA 0183 GPS for speed data to Stabilizer system, cable 9m.
8	SCU-12	<b>DMC SCU 2-fin</b> Included in all SCU-kits
9	151371-025	<b>SCU Power Cable 2.5m</b> Included in all SCU-kits
10	151375-100	<b>SCU Reverse Detection Cable 10m</b> Included in SCU-KIT-2F-SO, SCU-KIT-2F-ZF and SCU-KIT-2F-TD
11	151380	<b>Reversing Solenoid Interface w/dual relays</b> Included in SCU-KIT-2F-SO
12	321270	<b>Pressure switch 1/4" 0.1-1 bar NC</b> Included in SCU-KIT-2F-ZF
13	321272	<b>Pressure switch 1/4" 1-10 bar NC</b> Included in SCU-KIT-2F-TD
14	<b>SCU cable</b>	<b>Available in different lengths</b> Different length on port and starboard side can be used.
	151370-040	SCU-FCU cable 4m
	151370-070	SCU-FCU cable 7m
	151370-100	SCU-FCU cable 10m
	151370-150	SCU-FCU cable 15m
	151370-200	SCU-FCU cable 20m
	151370-250	SCU-FCU cable 25m
	151370-300	SCU-FCU cable 30m
15	Fuse	<b>Not supplied by Sleipner</b> Fuses for SCU and power cables.
16	Power cable	<b>Not supplied by Sleipner</b> For voltage supply to actuator. One black and one red crimp connector included with the actuator.
17	Ground wire	<b>Not supplied by Sleipner</b> For connection between vessel's main bonding system and actuator.
18	Multi-Functional Displays	<b>Not supplied by Sleipner</b> Optional. MFDs can be used for monitoring and configuration of thruster and stabilizer systems when connected to SDI-1. TP-43A is always required.

**Use of the alignment tool:**

Use the supplied bracket as an auxiliary tool in the keel alignment process.

1. Clamp a straightedge ruler to the bracket. The recommended distance "L" is depended of the actuator type, see the table below.

Actuator type	SPS40E	SPS50E	SPS60E	SPS70E	SPS80E	SPS100E
Distance "L"	600 mm	800 mm	800 mm	1200 mm	1200 mm	1500 mm

Before performing the keel alignment procedure, assemble the alignment tool to the actuator:

2. Align the bracket with the bump on the actuator fin hub.
3. Enter the screws in the corresponding holes on the actuator hub and tighten.

When the bracket with the straightedge ruler is assembled to the actuator, the actuator centerpoint will be at the indicated position "C".

Perform the Keel alignment procedure as described on the following page.

Verify that the straight ruler on the alignment tool is parallel to the keel by ensuring that the distance from both A and B to the keel center is approximately equal to the distance between the actuator centerpoint "C" and the keel center.

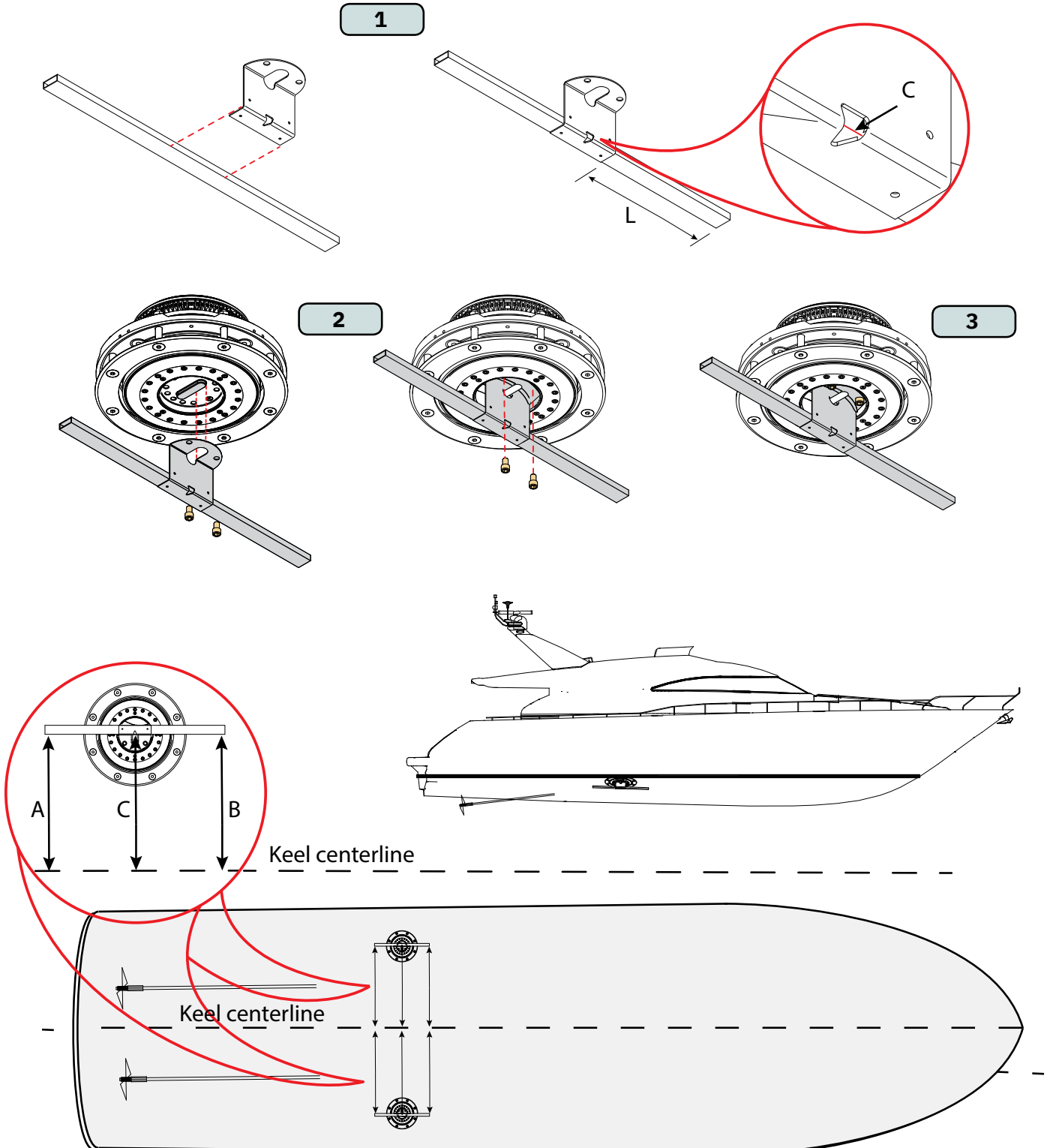

## CAUTION

Keep clear of the alignment tool during startup of the system. It may rotate, and a possible danger of personal injuries.

### Preparations

The keel alignment procedure must be carried out with the vessel on shore, before the fins are mounted.

This is a one-time procedure. Do not repeat unless an actuator encoder has been replaced.  
If the vessel is out of water and fin is installed, the procedure will fail.

- Verify that the complete stabilizer system with all its components are correctly installed and wired.
- Install the fin alignment tool to the actuator according to the “Keel alignment tool setup” procedure.
- Turn the complete system ON. (S-link, TP43, SCU)
- “Wake up” the TP-43 panel if it is dark by touching the ON/OFF button.
- Select the “Startup and maintenance” menu.
- Enter the PIN code (1234 -> Enter)



### Keel alignment setup procedure

From the TP-43 panel Startup and maintenance menu:

1. Select Setup
  2. Select Fin installation.
  3. Select Port
  4. Select correct actuator from the dropdown menu.
  5. Select correct fin type from the dropdown menu.
  6. Select Next.
  7. Select “Start motor self tuning”, and wait until the process is completed.
- Measure the distance perpendicular from the keel to each end of the alignment tool.
8. Press “Left” or “Right” button to adjust the actuator alignment tool parallel with the keel.
  9. Press the “Done” button when ready.
- Repeat steps 3 - 9 for the starboard fin.

When completed, return to fin installation procedure

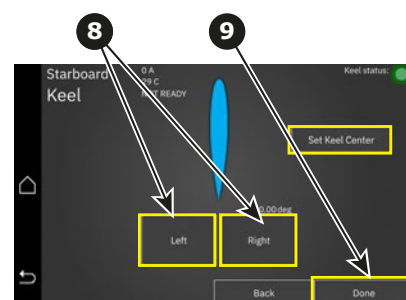
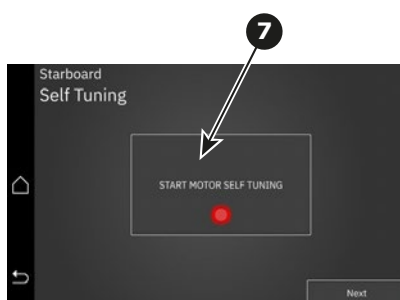
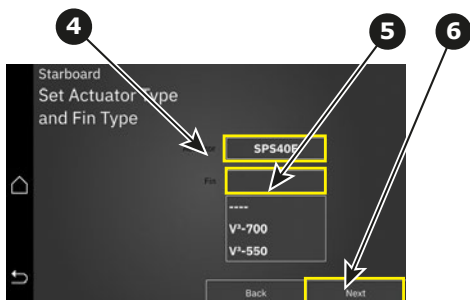
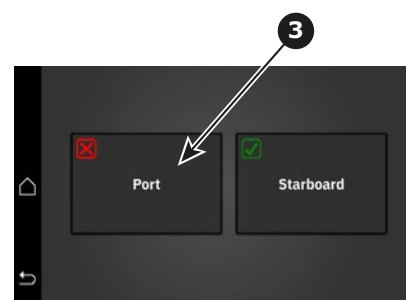
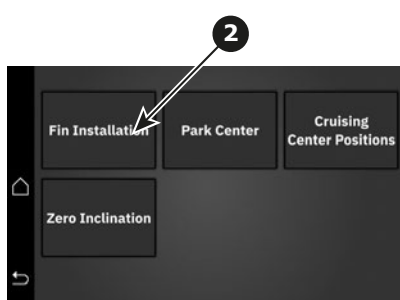
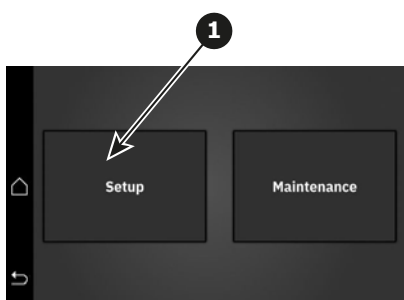

# Fin Components

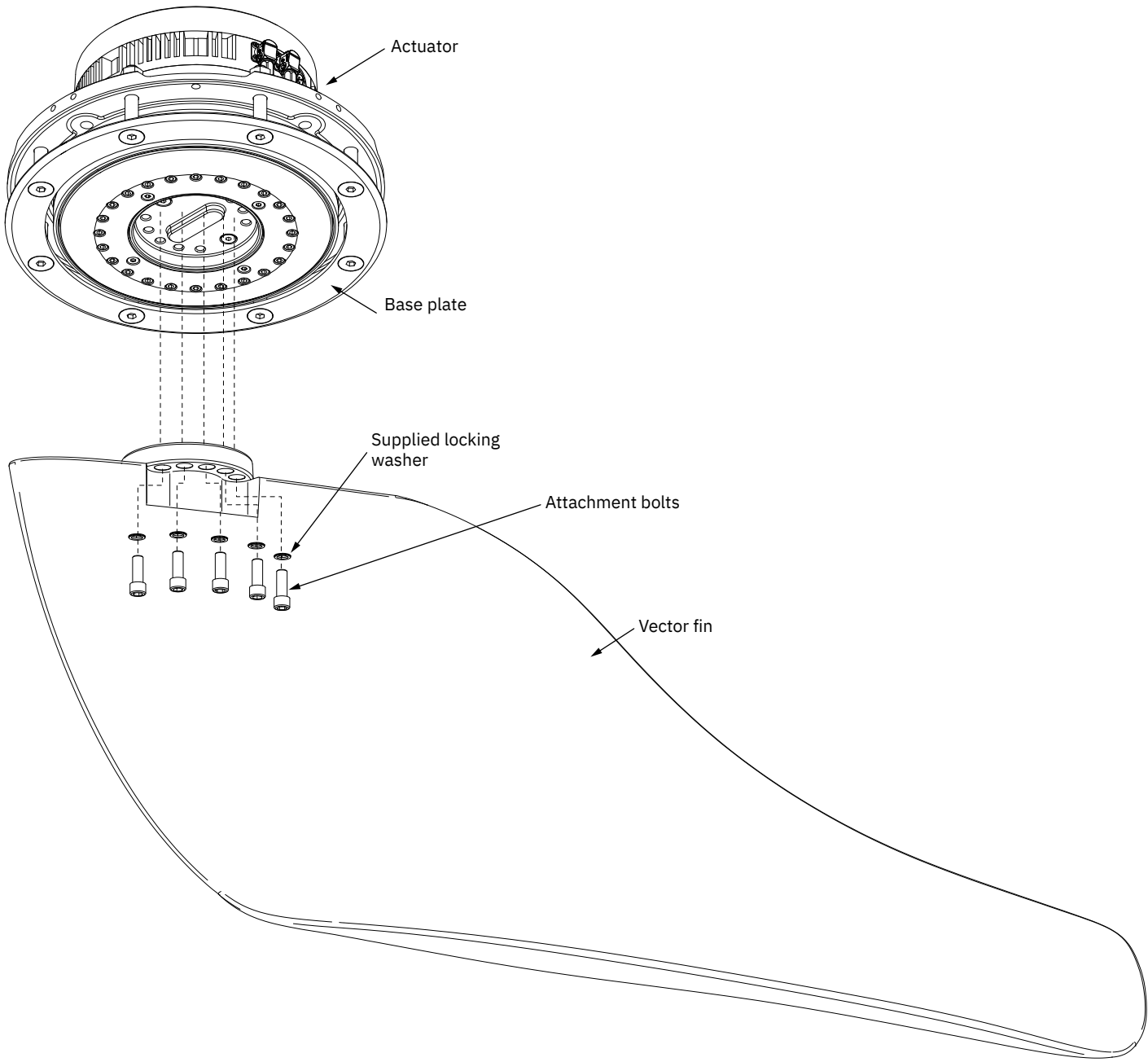

*! Please refer to the graphic for special considerations relating to your model !*

1. Align tongue and groove on the fin and the fin hub. **(NB: Do not apply grease to the bolt holes or the surface plate of the fin.)**
2. Place the locking washer to each bolt and apply a small amount of lubricant to the bolt threads. Insert the 10 attachment bolts to the fin.
3. Lift the fin into position.

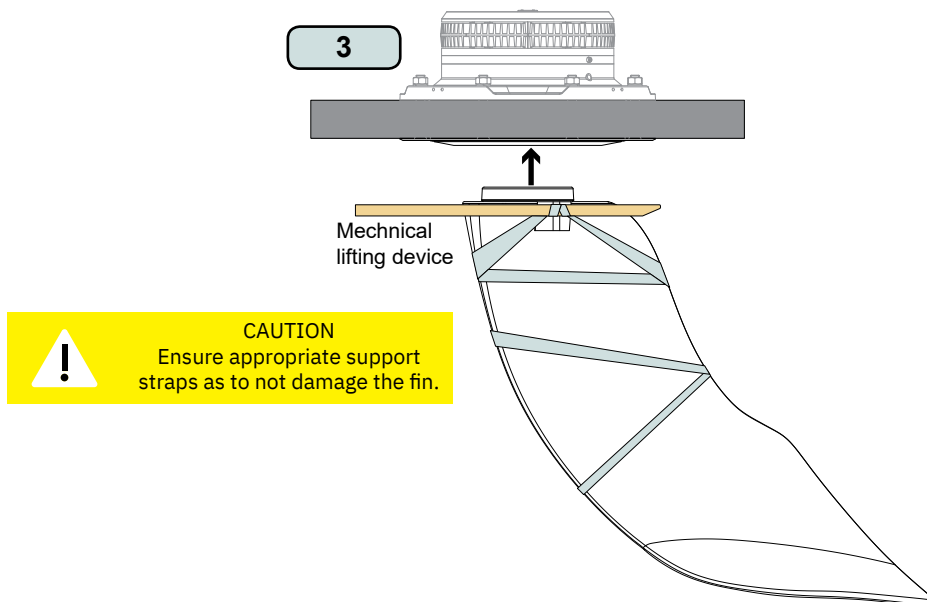
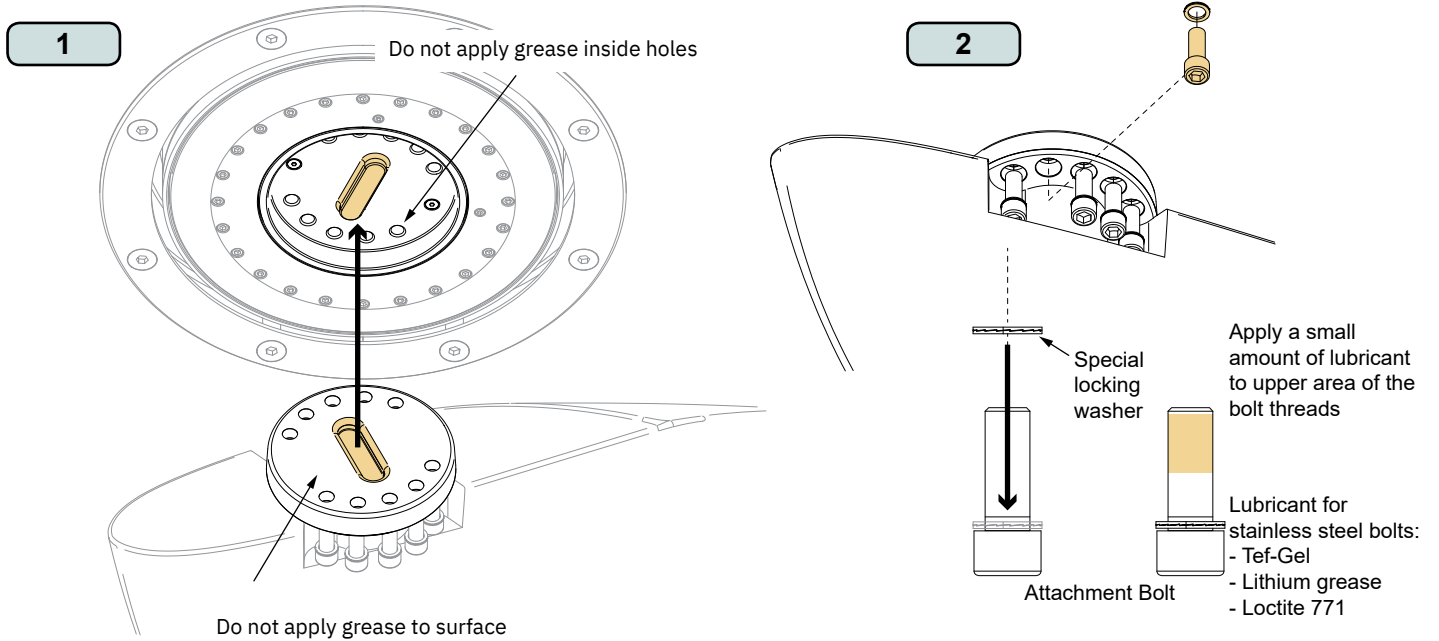



*! Please refer to the graphic for special considerations relating to your model !*

4. Tighten & torque load the 10 attachment bolts in two stages following the defined number order.  
 Stage 1: Fasten each bolt to the defined tightening value and order.  
 Stage 2: Fasten each bolt to the defined tightening value and order.
5. Attached shaft covers.

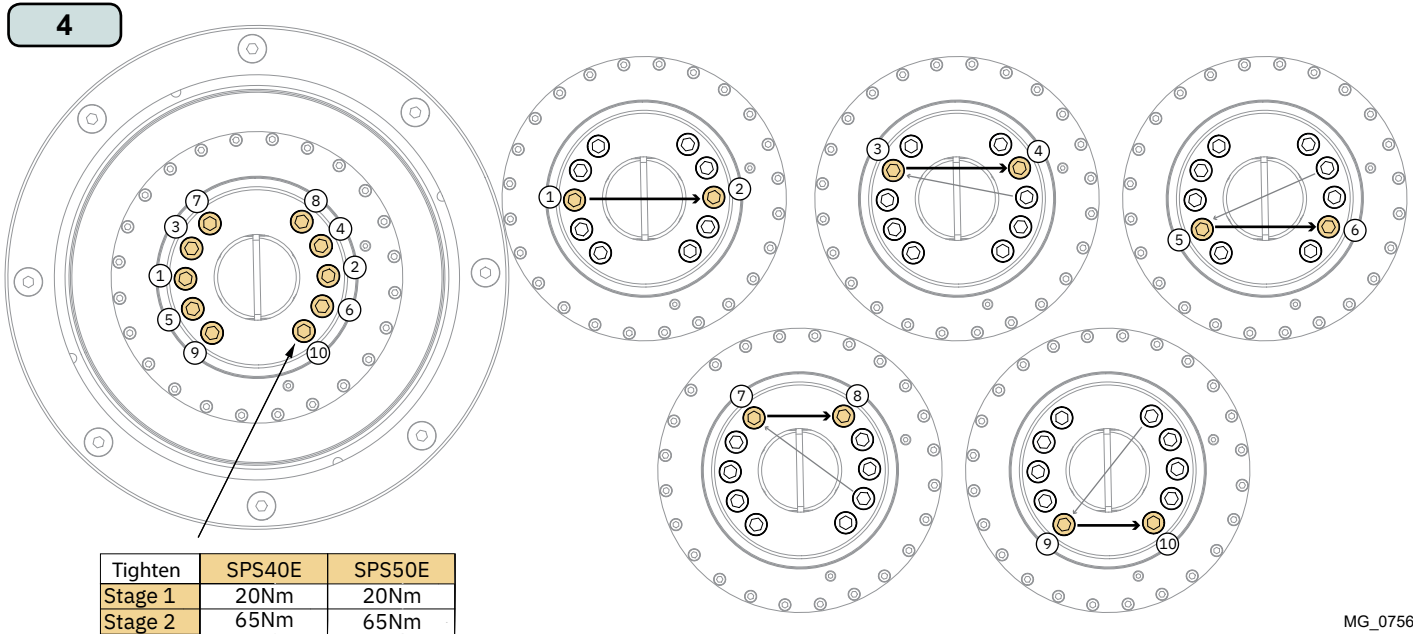

MG\_0756

1. Apply threadlock, e.g Loctire 243, on the setscrews, enter them in to the countersunk screwheads, and screw them all the way in.
2. Place the shaft cover in the fin, and enter the premounted screwheads.
- NOTE: The two shaft covers are not equal, they only fit in one of the sides each. This is easy to identify.**
3. Place the other cover in the opposite side of the fin. Apply threadlock on the setscrew, and enter the screwheads on the setscrews. Screw them all the way in, and tighten.

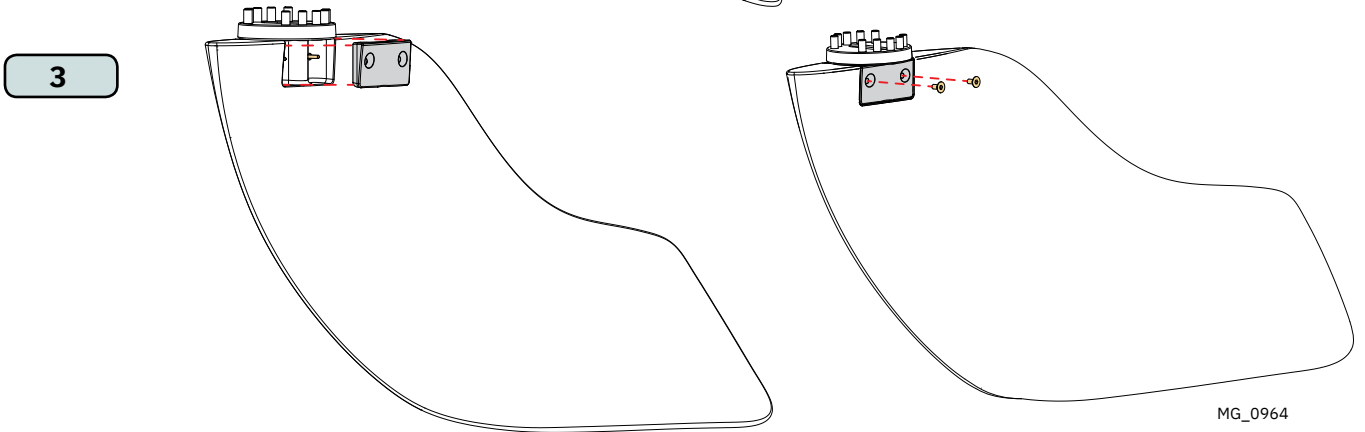
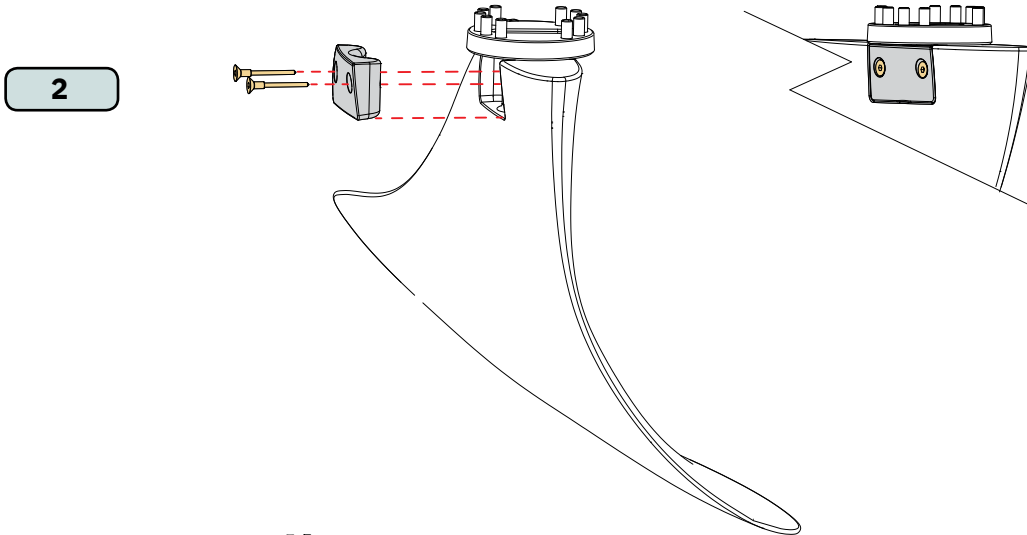
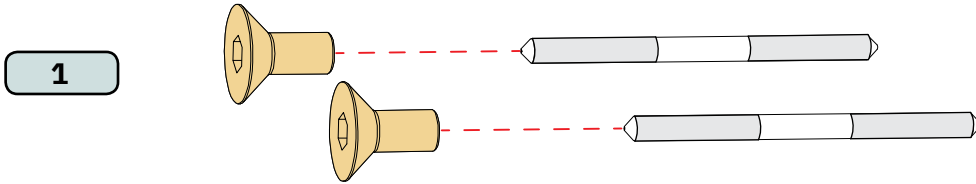

MG\_0964

### Purpose

The purpose with this set up is to calibrate the vessels horizontal position in to the stabilizer system. This is important for the system to operate correctly.

The zero inclination procedure can be performed at any time, either on shore or at sea, but before the Sea trial procedure.

### Preparation

Ensure that the vessel is in horizontal position in the sideways direction. If not possible, jump to the “Manual calibration” section.

#### Automatic calibration:

1. From the main menu, select the “Startup and maintenance” menu, and enter the PIN code (1234 -> Enter)
2. Select the “Setup” menu
3. Select the “Zero inclination” menu.
4. Select “Start”, and the system will calibrate.
  - Wait until the process is completed (Approx. 5 sec).

#### Manual calibration:

- Verify the vessels deviation from the horizontal sideways position.
  - Perform the steps 1 to 3 in the Automatic calibration procedure above.
5. Select “Zero inclination offset”.
    - Vessel heeling to the port side - enter a positive value. Vessel heeling to the starboard side - enter a negative value
  6. Enter the roll angle offset value in the numeric keyboard that shows up.
  7. Press enter in the numeric keyboard.
  8. Verify that the value shown in the stabilizer view corresponds with the vessel heeling.

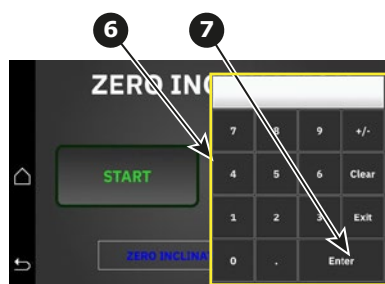
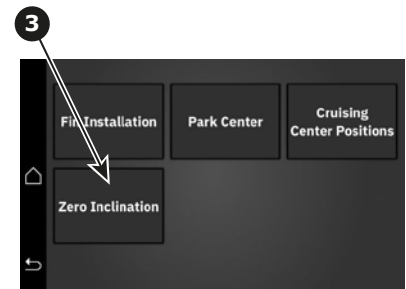
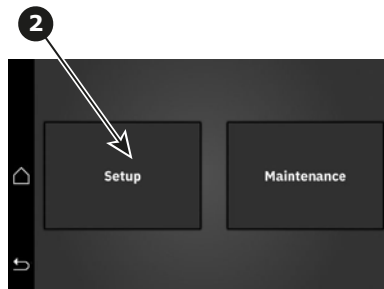

MG\_0938

## Purpose

Dynamic centers allowing the fins to operate at the ideal attack angle depending on the boat speed. By unlocking the fins and let them free float in five different speeds in the vessels speed range, the system will operate with the ideal angle of attack throughout the vessels speed range. This will minimize the drag from the fins, and also reduce the fuel consumption. This is illustrated as an example in the figure below. The fin position will be interpolated between the different speeds, so it is important to have speed both before and after the planing mode, as the water flow over the fins often changes during the transition to planing mode.

Run the vessel on flat water, or, if not possible, with the waves straight against the bow to minimize roll. Keep a steady course during the setting process. It is not possible to get a good result in large wave conditions.

If the vessel has interceptors or trim flaps, these are to be used as normal during the setup procedure.

Speeds must be increasing, i.e. speed 1 is the lowest speed and speed 5 is the top speed.

Speed 1 is normally set close to parked position, to reduce the roll movement of the vessel when turning off the system, which will center the fins.

## Procedure

- From the main menu, select the "Startup and maintenance" menu, and enter the PIN code (1234 -> Enter) (**Reference 1**).
- Select the "Setup" menu. (**Reference 2**).
- Select the "Cruising center positions" menu. (**Reference 3**).
- Select the "Unlock fins" menu. (**Reference 4**).
- Select "Start". (**Reference 5**).
- Set idle speed forward. Select "Speed 1" in the dropdown menu (**Reference 6**).
- When the speed is constant, and fin positions are stable, press "Store" (**Reference 7**) to register the speed and corresponding fin position.
- Proceed through the speed settings 2 to 5.
- Note that it also is possible to enter the speed and fin position manually.
- For each speed, while the stabilizer system is active, use the lift setting to optimize the boat speed.
- Note that it also is possible to enter the speed and fin position manually.

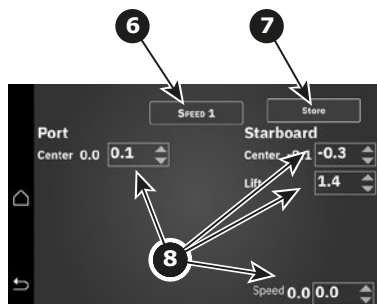
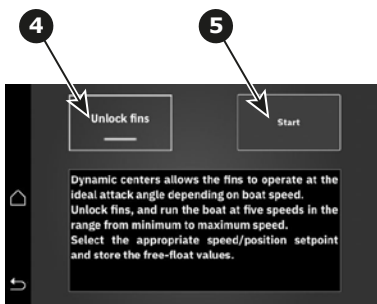
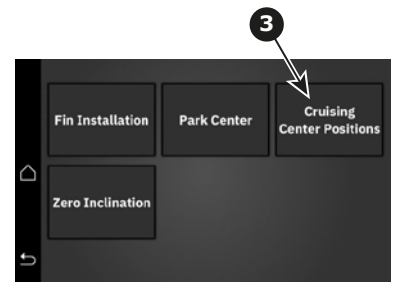
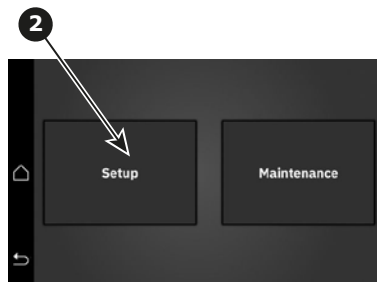
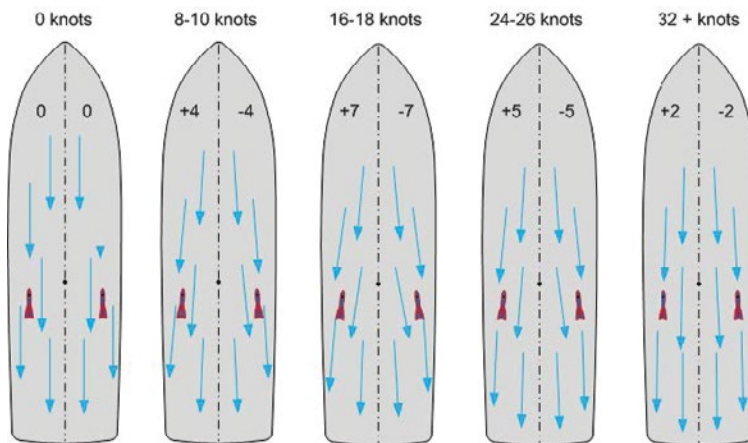

## Stabilizer settings procedure

The setting parameters in the Stabilizing, Optimization and Fin/Actuator tabs in the settings menu will differ from vessel to vessel. Generic parameters is set as standard values in the system. Sleipner can provide more specific parameters for certain hull / vessel types. Contact your dealer for more info.

Anyhow; the parameters in the Settings -> Handling tab must be set by the installer.

## Handling tab settings

1. Select the "Settings" menu.
2. Select the "Handling" tab
3. Select Backing detection, and select the correct input from the dropdown menu.
4. Select SCU Mount direction and select the SCU installation direction from the dropdown menu.  
This refers to how the SCU is mounted, see installation manual for reference.

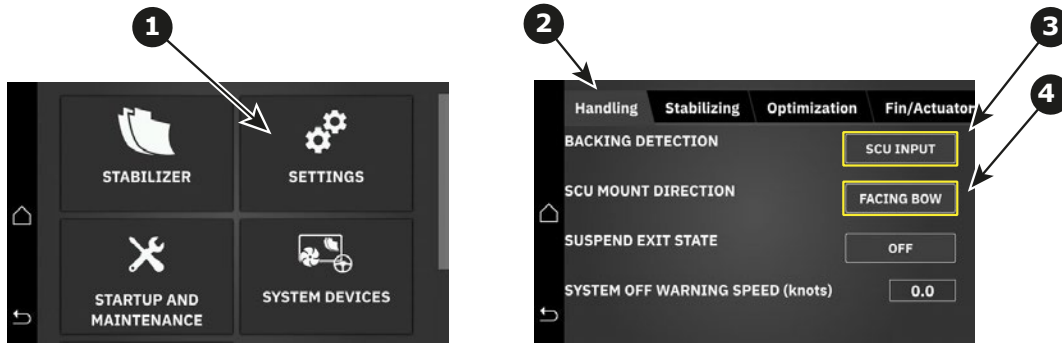

## Stabilizing-, Optimization-, and Fin/Actuator tabs

The setting parameters will differ from vessel to vessel. In order to have a easy set up procedure, generic parameters is set as standard values in the system.

**Sleipner will provide more specific parameters for certain hull / vessel types. Contact your dealer for more info.**

**The numbers shown in the illustrations below are just examples and not to be used.**

The boat builder or advanced users are able to optimize and set new values for all the parameters for optimizing the system to the vessel.

When it is necessary to enter new values:

Select the value that need to be changed, a keyboard shows up in the display. Enter the new value, and confirm.

The Stabilizing-, Optimization- and Fin/Actuator tabs are quite similar in sub menus and how to adjust the values. As an example, the Stabilizing tabs are shown in the illustrations below.

The menu tabs has sub menus; At anchor (**Reference 1**) and Cruising (**Reference 2**).

The parameter values are changed by selecting the numeric value connected to the actual parameter (**Reference 3**), and entering the new value in the numeric keyboard that shows up in the display. Confirm with enter on the keyboard.

Slide the side bar (**Reference 4**) to see all the parameter settings in the menus.

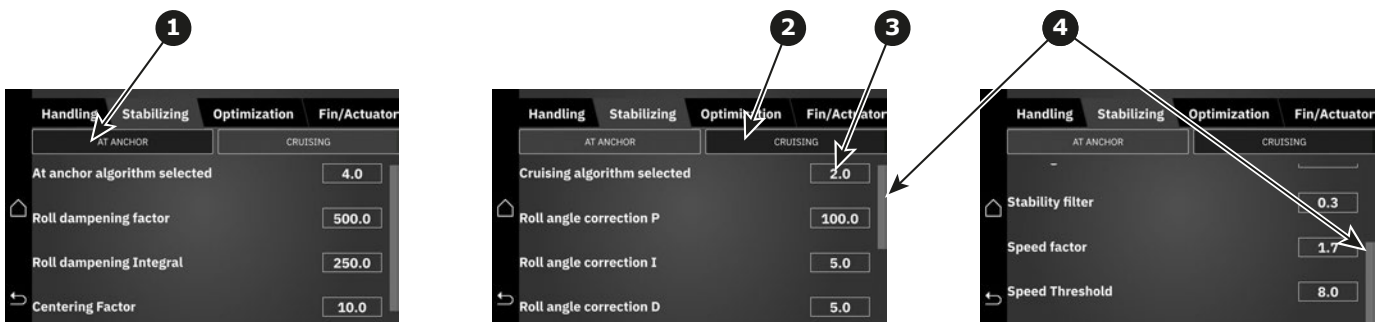

## Fin Location Label

After final installation of the fins place the Fin Location Labels to appropriately identify the location of the fins underwater.

### Safety Labels

To ensure crane operators and swimmers are aware of the fin's location and operation area, please mount the safety labels on the hull



**Adjustable length, fits all Sleipner Vector Fins™.**

For application, get your ✂ and follow instructions in the manual.

Use scissors to cut the end arrow symbols on the label.

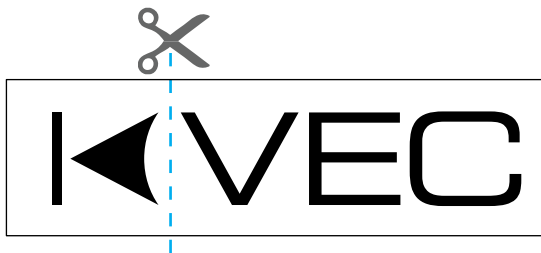

Place the label to the hull and place the end arrow labels to cover the length of the stabiliser fin.



Label designs ✂

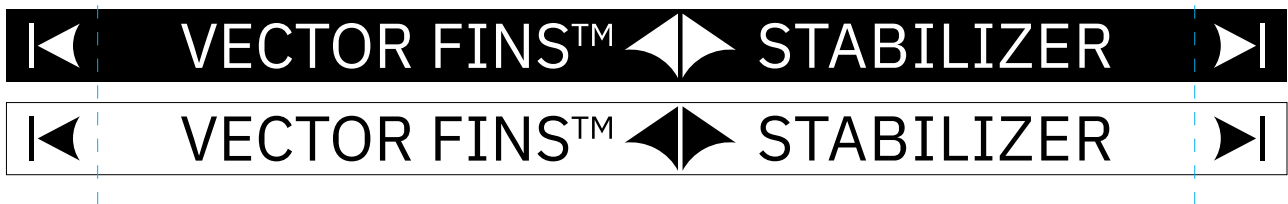

**Introduction:**

At Sleipner Group, we prioritize sustainability and encourage the repair and re-manufacturing of products to extend their life cycles. If disposal is necessary, please follow these guidelines to recycle and manage waste responsibly, ensuring our efforts align with environmental protection efforts.

**Electric Motors and Electronics:**

- Disconnect from any power sources and dismantle them carefully.
- Recycle components through certified e-waste recycling centers that can adequately handle and recover electronic materials.
- Dispose of any non-recyclable electronic parts according to local environmental regulations.

**Metals:**

- Collect and sort metal parts for recycling as scrap metal.
- To increase recycling efficiency, ensure that metals are clean and free from non-metal attachments.

**Plastics:**

- Identify recyclable plastics based on local recycling guidelines.
- Remove any non-plastic components and clean them before recycling to improve the quality of the recycled material.

**Hazardous Materials:**

- Correctly identify any hazardous substances within components, such as batteries or capacitors etc.
- Follow local regulations for the safe disposal of hazardous materials to prevent pollution and protect environmental health.

**General Disposal Instructions:**

- Consult local recycling programs to determine the acceptability of various materials.
- Use authorized disposal services to ensure compliance with environmental standards.

**Safe Disposal Practices:**

- Adhere to local laws and regulations for waste management to minimize environmental impact and ensure community safety.

This guide is designed to help reduce our products' environmental footprint through responsible end-of-life management. Please contact your local waste management supplier or our support team for more specific disposal information or further assistance.

**Find your local professional dealer from our certified worldwide network for expert service and support. visit our website [www.sleipnergrouper.com/support](http://www.sleipnergrouper.com/support)**

## Product spare parts and additional resources

**For additional supporting documentation, we advise you to visit our website [www.sleipnergrouper.com](http://www.sleipnergrouper.com) and find your Sleipner product.**

## Warranty statement

1. Sleipner Motor AS (The “Warrantor”) warrants that the equipment (parts, materials, and embedded software of products) manufactured by the Warrantor is free from defects in workmanship and materials for purpose for which the equipment is intended and under normal use and maintenance service (the “Warranty”).
2. This Warranty is in effect for two years (Leisure Use) or one year (Commercial and other Non-leisure Use) from the date of delivery/purchase by the end user, with the following exceptions;
  - (a) For demonstration vessels, or vessels kept on the water, the dealer is considered as the end user from 6 months after their launch of the vessel;
  - (b) The warranty period starts no later than 18 months after the first launch of the vessel.

Please note that the boat manufacturer and dealer must pay particular attention to correct maintenance and service both by the products manuals as well as general good practice for the location the boat is kept in the period the boat is in their care. In cases where the 6 and 18 months grace periods for boat builders and dealers are passed, it is possible to obtain a full warranty upon inspection and approval of the warrantor or such representative.
3. Certain parts, classified as wearable or service parts, are not covered by the warranty. A failure to follow the required maintenance and service work as described in the product manual render all warranty on parts or components directly or indirectly affected by this void. Please also note that for some parts, time is also a factor separately from actual operational hours.
4. This Warranty is transferable and covers the equipment for the specified warranty period.
5. The warranty does not apply to defects or damages caused by faulty installation or hook-up, abuse or misuse of the equipment including exposure to excessive heat, salt or fresh water spray, or water immersion except for equipment specifically designed as waterproof.
6. In case the equipment seems to be defective, the warranty holder (the “Claimant”) must do the following to make a claim:
  - (a) Contact the dealer or service centre where the equipment was purchased and make the claim. Alternatively, the Claimant can make the claim to a dealer or service centre found at [www.sleipnergrouper.com](http://www.sleipnergrouper.com). The Claimant must present a detailed written statement of the nature and circumstances of the defect, to the best of the Claimant’s knowledge, including product identification and serial nbr., the date and place of purchase and the name and address of the installer. Proof of purchase date should be included with the claim, to verify that the warranty period has not expired;
  - (b) Make the equipment available for troubleshooting and repair, with direct and workable access, including dismantling of furnishings or similar, if any, either at the premises of the Warrantor or an authorised service representative approved by the Warrantor. Equipment can only be returned to the Warrantor or an authorised service representative for repair following a pre-approval by the Warrantor’s Help Desk and if so, with the Return Authorisation Number visible postage/shipping prepaid and at the expense of the Claimant.
7. Examination and handling of the warranty claim:
  - (a) If upon the Warrantor’s or authorised service Representative’s examination, the defect is determined to result from defective material or workmanship in the warranty period, the equipment will be repaired or replaced at the Warrantor’s option without charge, and returned to the Purchaser at the Warrantor’s expense. If, on the other hand, the claim is determined to result from circumstances such as described in section 4 above or a result of wear and tear exceeding that for which the equipment is intended (e.g. commercial use of equipment intended for leisure use), the costs for the troubleshooting and repair shall be borne by the Claimant;
  - (b) No refund of the purchase price will be granted to the Claimant, unless the Warrantor is unable to remedy the defect after having a reasonable number of opportunities to do so. In the event that attempts to remedy the defect have failed, the Claimant may claim a refund of the purchase price, provided that the Claimant submits a statement in writing from a professional boating equipment supplier that the installation instructions of the Installation and Operation Manual have been complied with and that the defect remains.
8. Warranty service shall be performed only by the Warrantor, or an authorised service representative, and any attempt to remedy the defect by anyone else shall render this warranty void.
9. No other warranty is given beyond those described above, implied or otherwise, including any implied warranty of merchantability, fitness for a particular purpose other than the purpose for which the equipment is intended, and any other obligations on the part of the Warrantor or its employees and representatives.
10. There shall be no responsibility or liability whatsoever on the part of the Warrantor or its employees and representatives based on this Warranty for injury to any person or persons, or damage to property, loss of income or profit, or any other incidental, consequential or resulting damage or cost claimed to have been incurred through the use or sale of the equipment, including any possible failure or malfunction of the equipment or damages arising from collision with other vessels or objects.
11. This warranty gives you specific legal rights, and you may also have other rights which vary from country to country.

## Patents

At Sleipner we continually reinvest to develop and offer the latest technology in marine advancements. To see the many unique designs we have patented, visit our website [www.sleipnergrouper.com/patents](http://www.sleipnergrouper.com/patents)



© **Sleipner Motor AS**, All rights reserved

The information given in the document was right at the time it was published. However, Sleipner Motor AS cannot accept liability for any inaccuracies or omissions it may contain. Continuous product improvement may change the product specifications without notice. Therefore, Sleipner Motor AS cannot accept liability for any possible differences between product and document.

**Learn more about our products at**  
**[www.sleipnergroun.com](http://www.sleipnergroun.com)**



**SLEIPNER MOTOR AS**

P.O. Box 519

N-1612 Fredrikstad

Norway

[www.sleipnergroun.com](http://www.sleipnergroun.com)

Made in Norway