



# Service and Support

## IPC upgrade kit 55 - 75 (95/155)

**DOCUMENT ID: 3945**

**REVISION: 2**

**DATE: 2024**

**LANGUAGE: EN**

**SS**

## Kit

- 1 pcs. Control box (6 123...i)
- 1 pcs. Wiring loom (6 1226B)
- 1 pcs. Negative terminal / black cable (R10)

## Upgrade Procedure

1. Disconnect thruster batteries by disconnecting the mainswitch(es).
2. Disconnect the 4 way connector on the existing wiring loom (internal thruster wiring loom).
3. Disconnect the two cable connections on both sides of the solenoid (2 x red, 1 x blue and 1 x grey).
4. Loosen the middle bolt on top of the solenoid and remove the red cable.
5. Disconnect the 1 way connector on the thin wire coming out of the electric motor (over temperature function).
6. Remove existing wiring loom and control box.
7. Install the (R10) negative cable (included in kit) on the A1 terminal (battery negative) torque = 15 Nm.
8. Install the new control box (6 123...i) with the new wiring loom (6 1226B) on the existing holding bracket.
9. Connect blue, grey and red wires to the solenoid in accordance to the drawing on the next page. Torque for the nut on B+ = 8 Nm.
10. Loosen A2 cable and install new white cable with circular cable shoe, between the spring washer and A2 cable. Torque = 8 Nm.
11. Connect the black wire with the 1 way contact in the wiring loom, to the 1 way contact coming from A1 terminal.
12. Connect the brown wire with the 1 way contact in the wiring loom, to the 1 way contact coming from the electric motor (over temperature function).
13. Check that the connections are in accordance to the drawing on the next page.

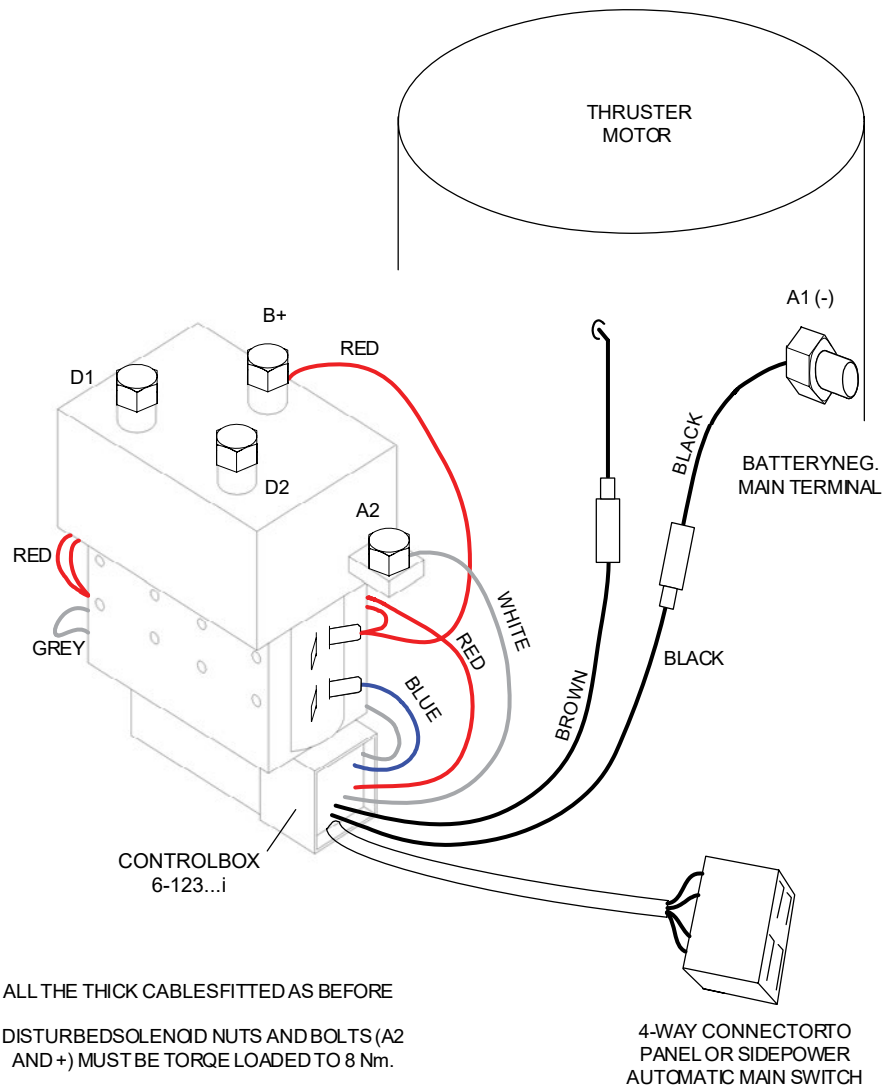

# Wiring Diagram with IPC Control Box

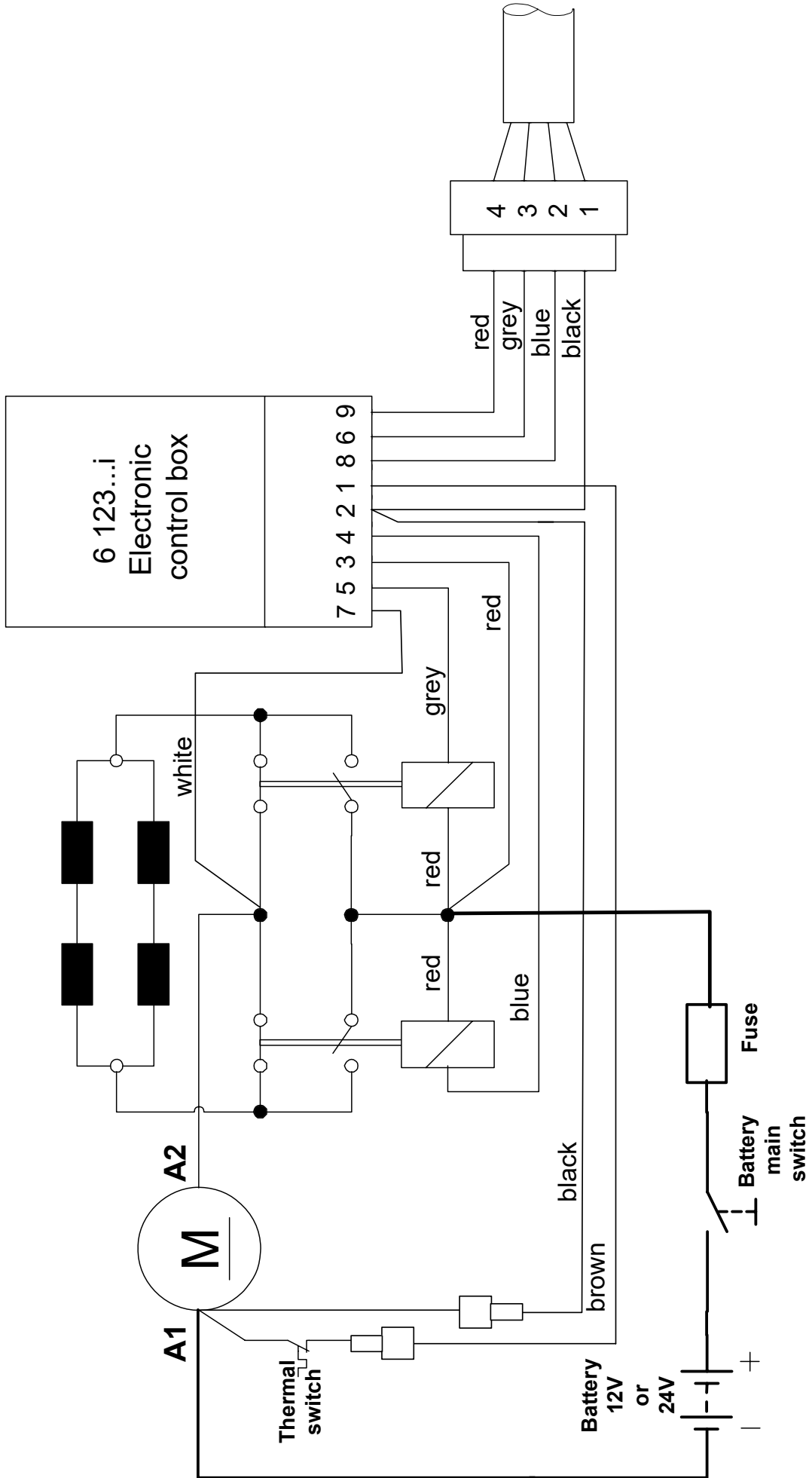

© **Sleipner Group**, All rights reserved  
The information given in the document  
was right at the time it was published.  
However, Sleipner Group cannot  
accept liability for any inaccuracies or  
omissions it may contain. Continuous  
product improvement may change the  
product specifications without notice.  
Therefore, Sleipner Group cannot accept  
liability for any possible differences  
between product and document.

**Learn more about our products at**  
**[www.sleipnergroun.com](http://www.sleipnergroun.com)**



**SLEIPNER MOTOR AS**

P.O. Box 519

N-1612 Fredrikstad

Norway

[www.sleipnergroun.com](http://www.sleipnergroun.com)

Made in Norway